

Update 2018

BONALDO



Update 2018

BONALDO

Bonaldo 2018, un viaggio attraverso nuove dimensioni dell'abitare

Bonaldo 2018, a journey through new dimensions of living

Una collezione di storie e suggestioni internazionali.

Dietro la Collezione 2018 di Bonaldo c'è la capacità di raccontare le nuove dimensioni dell'abitare, all'insegna di un "total living" impreziosito dall'artigianato italiano. A dar voce a questa narrazione corale sono proposte frutto di collaborazioni internazionali, consolidate o inedite, sapientemente dirette da Bonaldo per creare un linguaggio estetico coeso. Talenti emergenti e designer affermati, ciascuno col proprio stile e bagaglio emozionale,

consolidano il volto cosmopolita di un'azienda che si fa portavoce di prospettive inedite e ricordi personali. Così, Bonaldo diventa autrice di tante storie diverse che entrano in risonanza con chi ama uno stile interprete delle più contemporanee tendenze ed esigenze, vivificato da dinamici accostamenti cromatici e materici e dal valore tangibile del made in Italy.

Le nuove dimensioni dell'abitare

La Collezione Bonaldo 2018 è un viaggio attraverso l'abitare moderno fatto di sofisticate soluzioni estetiche e di un

design che danza in bilico tra stile classico e ironico. Forte di oltre 80 anni di attività, l'azienda riesce a convogliare molteplici visioni e prospettive entro un'unica, sfaccettata impronta stilistica: il segreto per mantenere un'identità riconoscibile e al tempo stesso evolversi, aprirsi al "total living" e rispondere a ogni esigenza d'arredo. Tavoli, sedute, complementi, divani e letti compongono una collezione che riserva un focus speciale agli imbottiti.



A collection of international stories and suggestions

The new dimensions of living are the main inspiration behind Bonaldo 2018 Collection, in pursuit of a 'total living' concept enhanced by Italian craftsmanship. This results in a choral narration of new designs by Italian and international creatives. A variety of new or consolidated partnerships expertly directed by Bonaldo to create a cohesive aesthetic language. Emerging talents and established designers, each with their own style and emotional

baggage, consolidate the global appeal of a company that gives voice to unusual points of view and personal memories. Thus, Bonaldo becomes the author of many different stories that resonate with those who love a style that interprets the most contemporary trends and needs, enhanced by dynamic color and material combinations and by the tangible value of Made in Italy.

The new dimensions of living

The Bonaldo 2018 Collection is a sophisticated journey through

modern living. The new designs stand out for a sophisticated aesthetic that embraces both classical and ironic style. More than 80 years of experience allow Bonaldo to convey multiple visions and perspectives within a single, multifaceted stylistic imprint: the secret to maintaining a recognizable identity while evolving at the same time, opening up to a 'total living' approach and meeting every furnishing need. Tables, chairs, accessories, sofas and beds make up a collection that reserves a special focus on upholstered furniture.



**Nuove finiture
e antico know-how per
uno stile che conquista
tutto il mondo**

La Collezione Bonaldo 2018 dà voce all'istanza di continuo rinnovamento che concorre all'identità del brand attraverso la sperimentazione di inedite finiture. In primis i colori, poi anche i nuovi materiali di pregio che si accostano ai più tradizionali legno, vetro, marmo e metallo: la finitura onice, che trasforma

gli arredi in raffinati gioielli, e il terrazzo veneziano, protagonista del 2018 ma soprattutto autentico omaggio alle origini dell'azienda. Esaltate dal know-how tecnologico e dal patrimonio artigianale veneto e contraddistinte da affascinanti linguaggi espressivi, le proposte diventano così protagoniste sulla scena internazionale, conquistando sempre nuovi mercati, dalla Cina all'Arabia Saudita, dal Sud America all'Australia.



**New finishes
and ancient know-how
for a style that conquers
the world**

It's experimenting with new materials and colors that Bonaldo manages continuous innovation. Apart from an enriched chromatic palette, the brand's 2018 Collection includes new, precious materials that are combined with the more traditional wood, glass, marble and metal: onyx finishing,

which turns the designs into refined jewels, and the Venetian terrace, one of 2018's top trends but above all an authentic homage to the company's origins. Enhanced by technological know-how and Italian craftsmanship and marked by fascinating expressive languages, the new proposals are conquering the international scene, with Bonaldo opening up to new markets, from China to Saudi Arabia, from South America to Australia.



Tavoli
Tables

- PAG 12-23 **Art** Gino Carollo
- PAG 34-41 **Prora** Mauro Lipparini
- PAG 24-33 **Tangle** Dondoli e Pocci
- PAG 42-45 **Truly** Mauro Lipparini

Sedie
Chairs

- PAG 64-67 **Benedetta** Dondoli e Pocci
- PAG 68-69 **Blues** Dondoli e Pocci
- PAG 74-75 **Giuseppina** Dondoli e Pocci
- PAG 70-71 **Idole** Dondoli e Pocci
- PAG 72-73 **Pangea** Dondoli e Pocci
- PAG 56-59 **Pil** Alessandro Busana
- PAG 48-55 **Stone** Fabrice Berrux
- PAG 60-63 **Why Not** Sergio Bicego

Complementi
Accessories

- PAG 96-99 **Bardot** Laura Cazzaniga e Ilaria Limonta
- PAG 78-83 **Cabinet de Curiosité** Fabrice Berrux
- PAG 88-89 **Day** Gino Carollo
- PAG 94-95 **Fragment** Alain Gilles
- PAG 90-91 **Movie** Gino Carollo
- PAG 92-93 **Note Sideboard 220 cm** Mario Mazzer
- PAG 84-87 **Outline** Mario Mazzer

Poltrone
Armchairs

- PAG 110-113 **Lock, Lock ego, Lock soft** Alessandro Busana
- PAG 104-105 **Lovy armchair bergère** Sergio Bicego
- PAG 102-103 **Lovy armchair low** Sergio Bicego
- PAG 106-109 **Tirella** Paolo Grasselli

Divani
Sofas

- PAG 134-137 **Arno sofa** Mauro Lipparini
- PAG 144-151 **Cortina** Mauro Lipparini
- PAG 142-143 **Lovy ego** Sergio Bicego
- PAG 138-141 **Lovy hi** Sergio Bicego
- PAG 126-133 **Madame C.** Giuseppe Viganò
- PAG 116-125 **Panorama** Fabrice Berrux

Letti
Beds

- PAG 160-165 **Kenobi** Mauro Lipparini
- PAG 154-159 **Youniverse** Mauro Lipparini

Tavoli / Tables



Sedie / Chairs

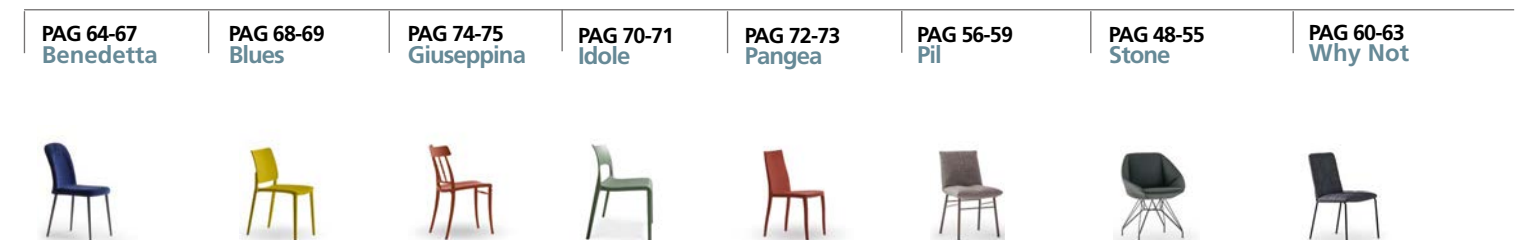

Complementi / Accessories

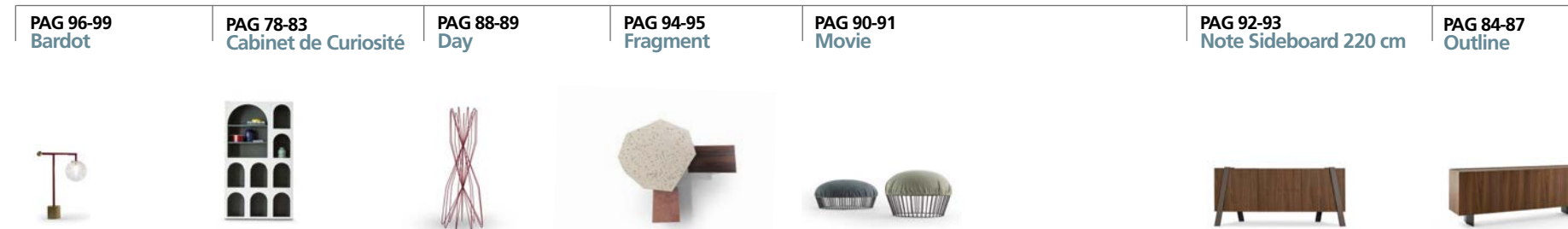

Poltrone / Armchairs



Divani / Sofas



Letti / Beds



Tavoli / Tables Art - Gino Carollo / **Prora** - Mauro Lipparini / **Tangle** - Dondoli e Pocci / **Truly** - Mauro Lipparini

Update - 2018 pag 10 - 11

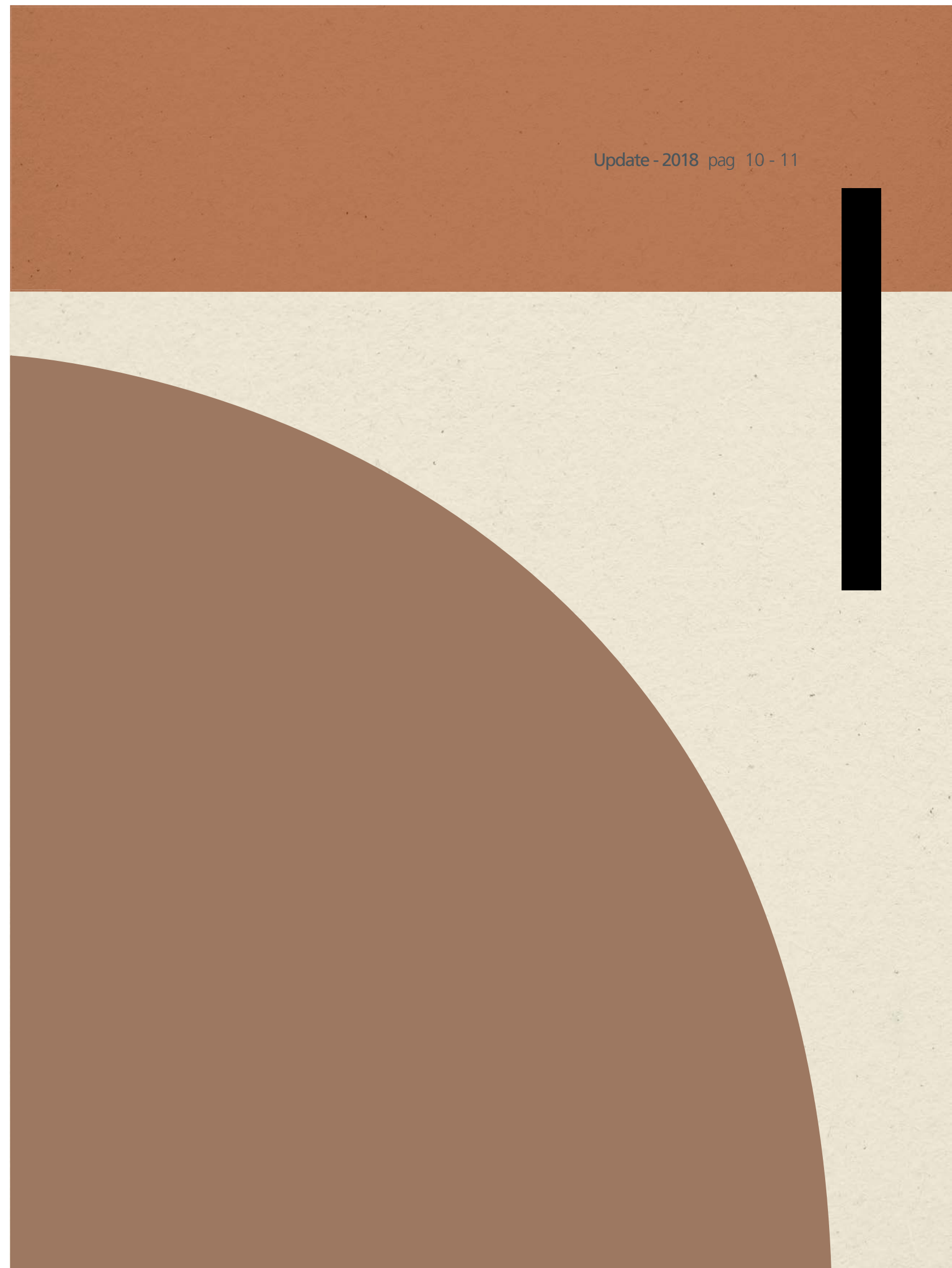



Art Gino Carollo

Update - 2018 pag 14 - 15



Art Gino Carollo



Update - 2018 pag 16 - 17







Art Gino Carollo - Versione allungabile / Leaf version



Update - 2018 pag 22 - 23





Tangle Dondoli e Pocci



Update - 2018 pag 26 - 27







Tangle 220 cm Dondoli e Pocci



Tangle 250 cm Dondoli e Pocci

Update - 2018 pag 32 - 33



Prora Octagonal Mauro Lipparini

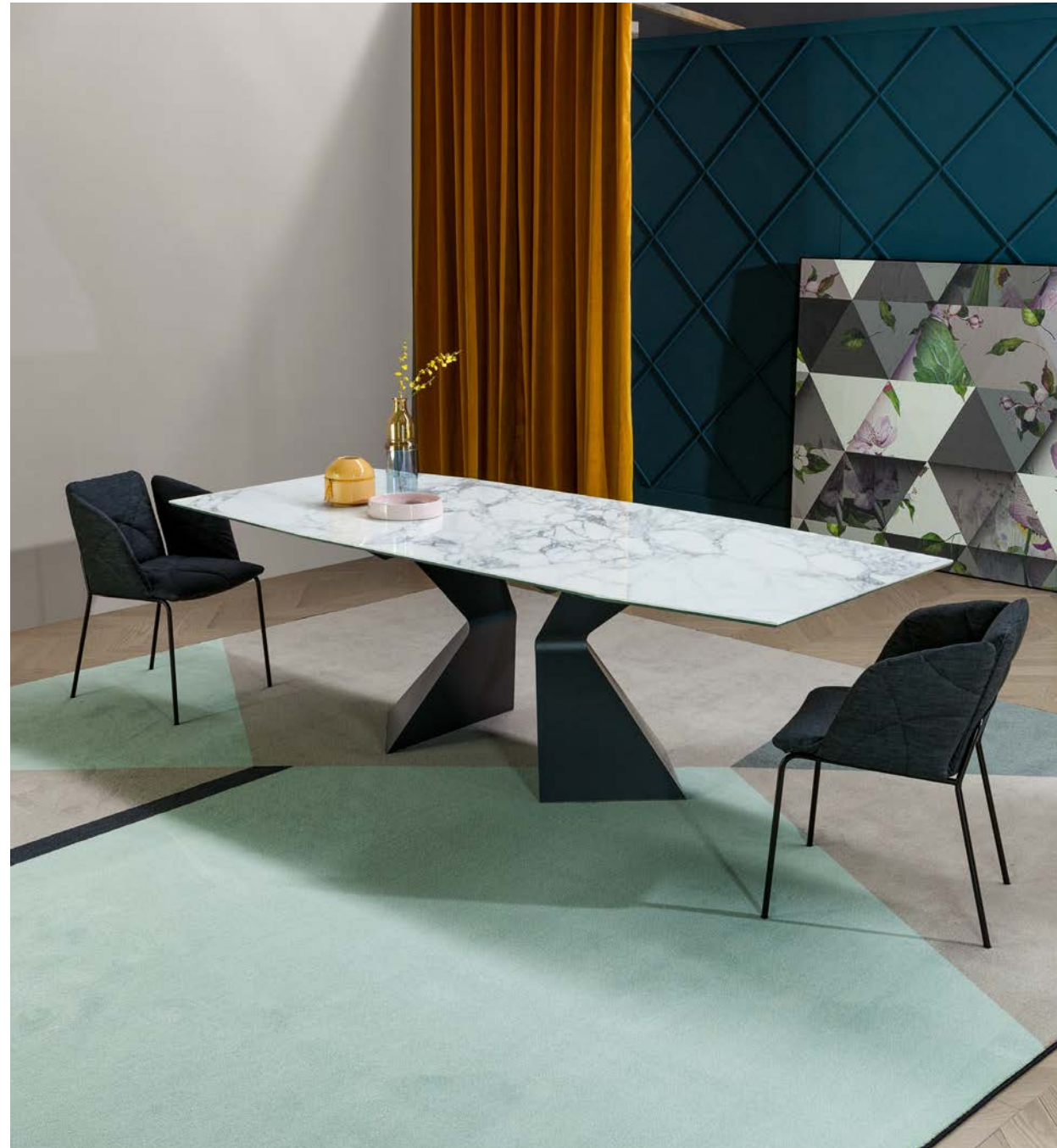





Prora Mauro Lipparini



Update - 2018 pag 40 - 41



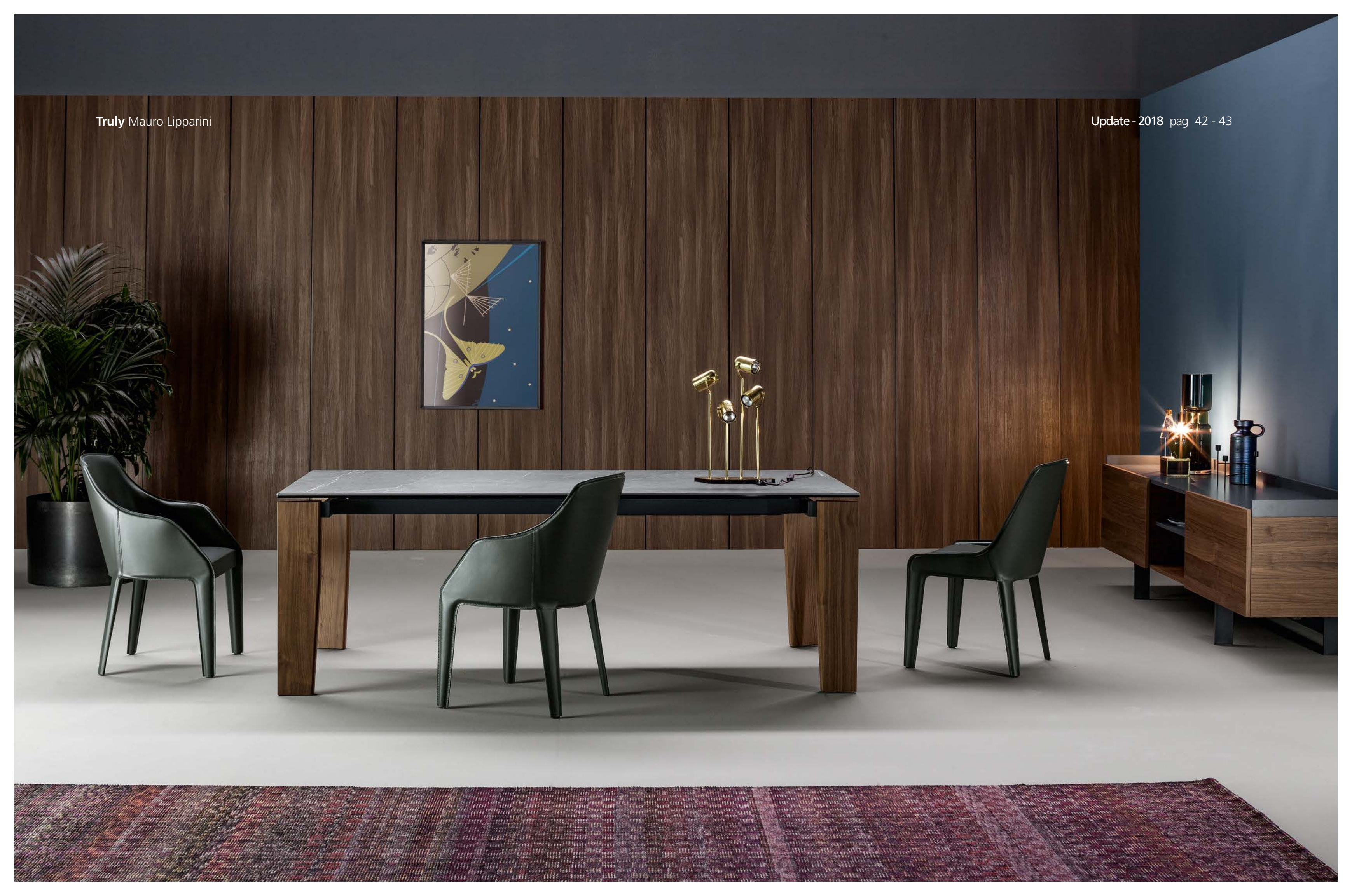

Truly Mauro Lipparini



Update - 2018 pag 44 - 45

Benedetta – Dondoli e Pucci
Blues – Dondoli e Pucci
Giuseppina – Dondoli e Pucci
Idole – Dondoli e Pucci
Pangea – Dondoli e Pucci
Pil – Alessandro Busana
Stone – Fabrice Berrux
Why Not – Sergio Bicego

Sedie / Chairs



Stone Fabrice Berrux

Update - 2018 pag 50 - 51



Stone Fabrice Berrux





Pil Alessandro Busana



Update - 2018 pag 56 - 57





Pil up



Pil



Pil too



Miss Pil

Miss Why Not Sergio Bicego

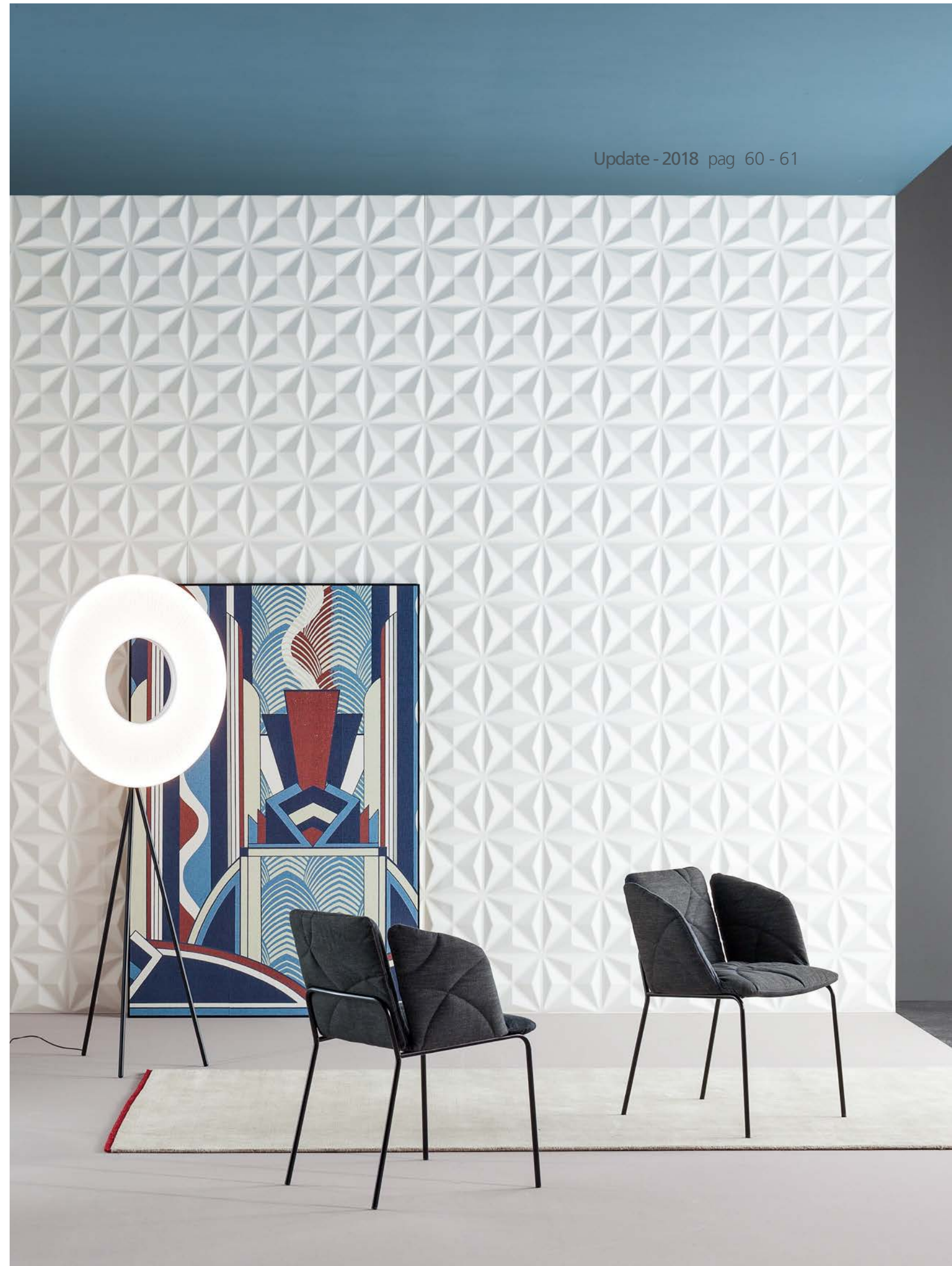

Why Not up Sergio Bicego



Update - 2018 pag 62 - 63



Benedetta up Dondoli e Poggi

Update - 2018 pag 64 - 65



Benedetta Dondoli e Pucci



Benedetta, Benedetta up Dondoli e Pucci

Update - 2018 pag 66 - 67











Complementi / Accessories

Bardot

Cabinet de Curiosité – Fabrice Berrux

Day – Gino Carollo

Fragment – Alain Gilles

Movie – Gino Carollo

Note Sideboard 220 cm – Mario Mazzer

Outline – Mario Mazzer



Cabinet de Curiosité Fabrice Berrux



Cabinet de Curiosité Fabrice Berrux



Outline Mario Mazzer

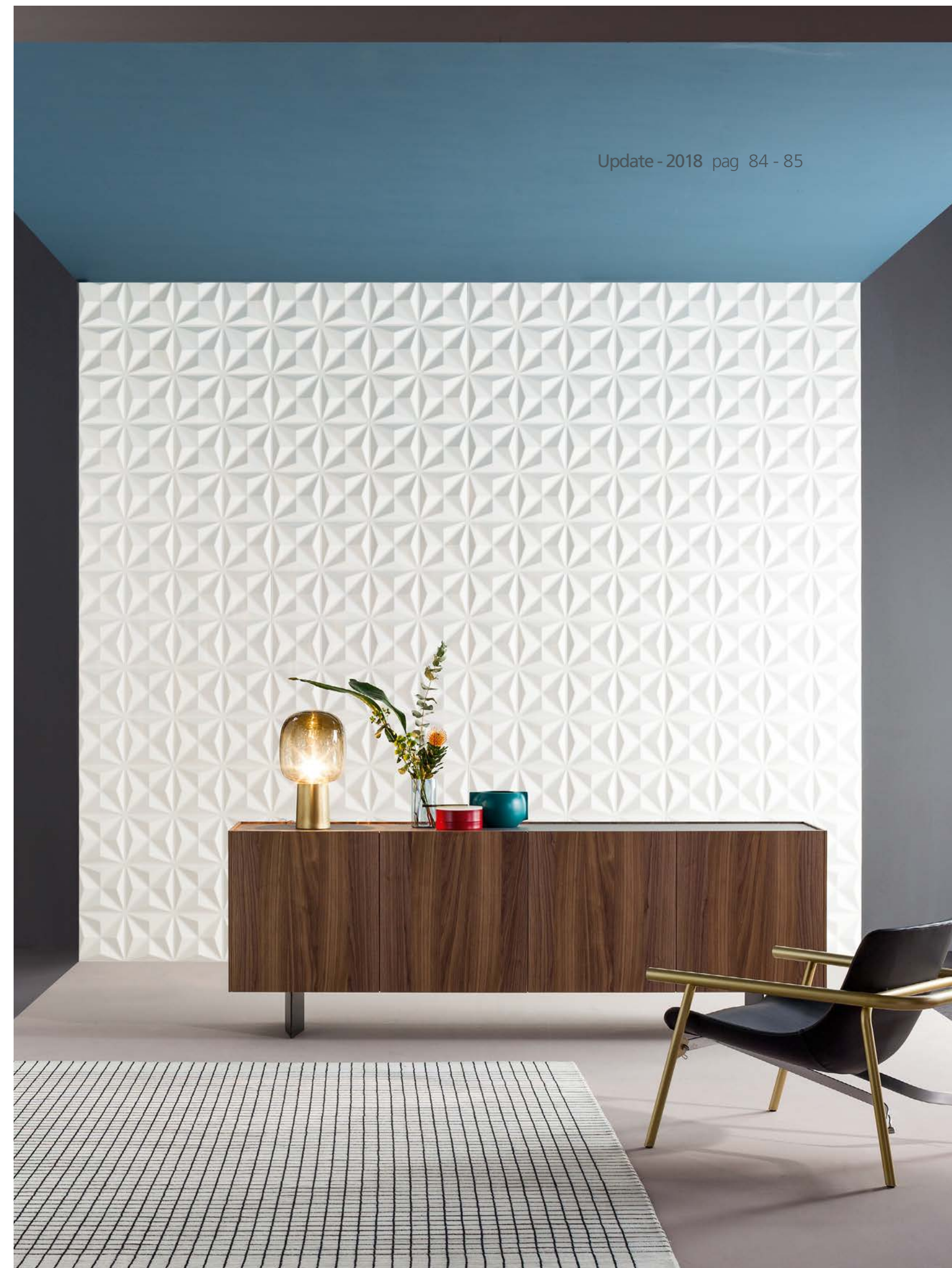

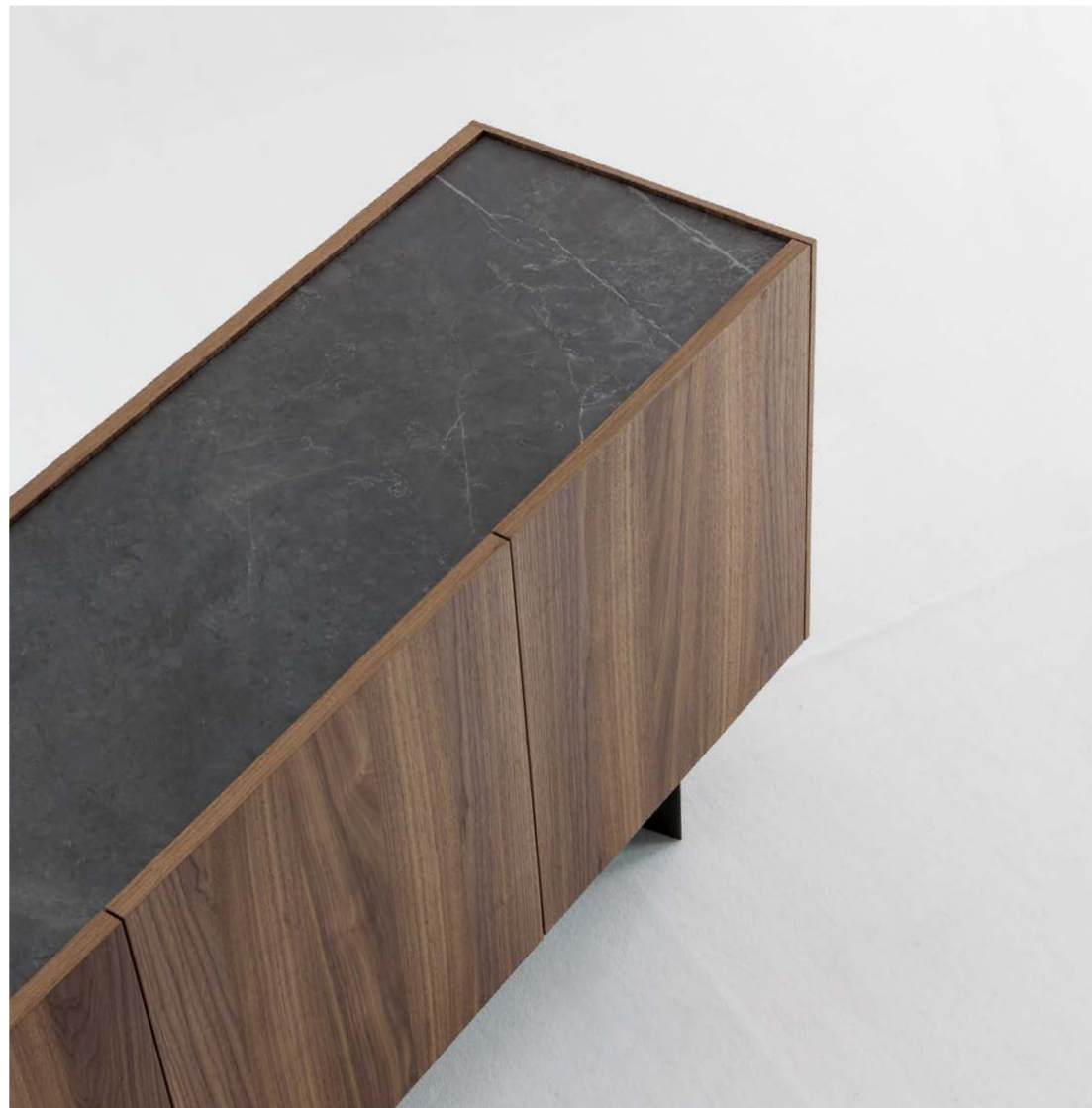

Day Gino Carollo



Update - 2018 pag 88 - 89

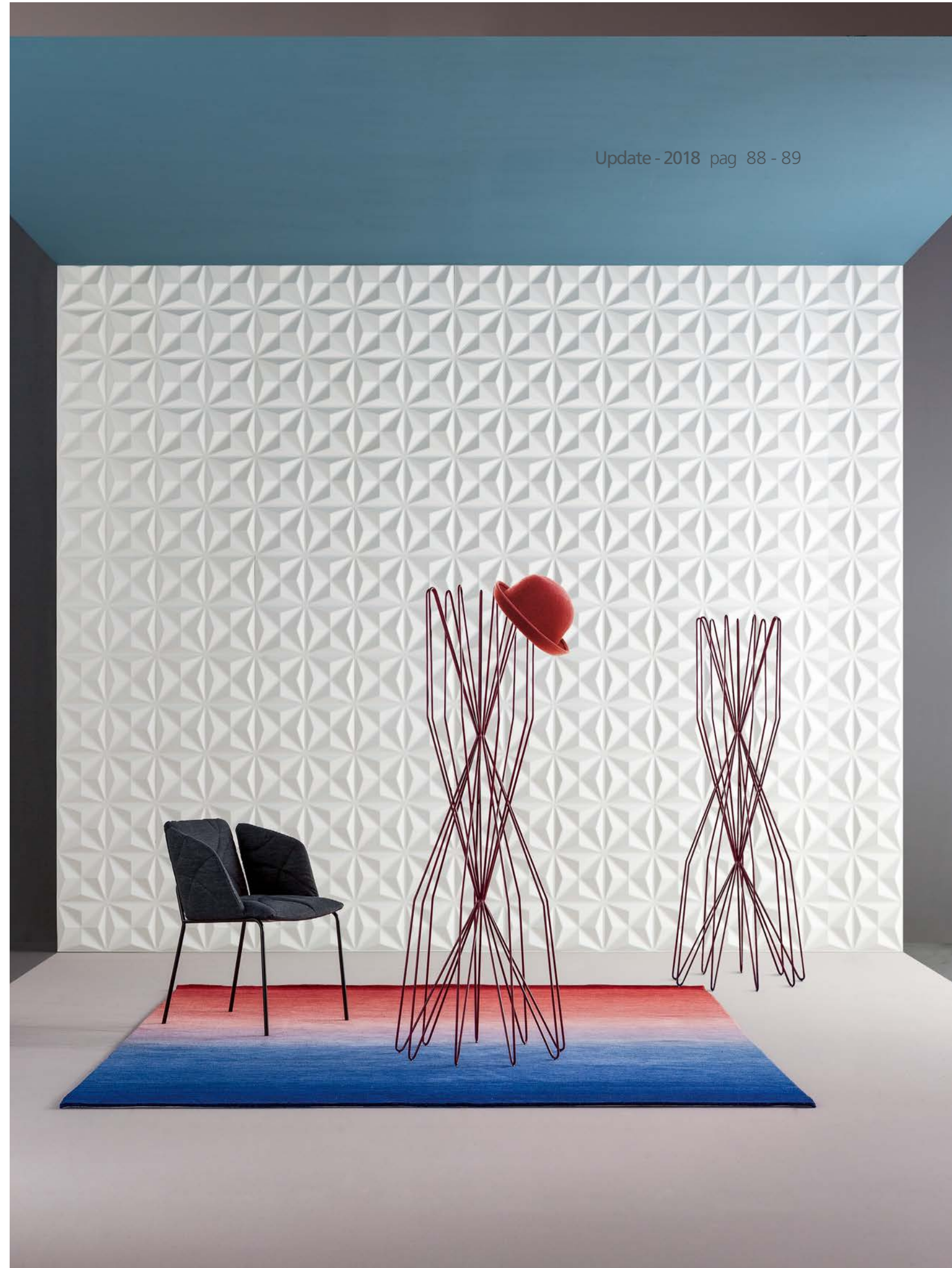

Movie Gino Carollo



Update - 2018 pag 90 - 91



Note Sideboard 220 cm Mario Mazzer



Update - 2018 pag 92 - 93



Fragment Alain Gilles



Update - 2018 pag 94 - 95

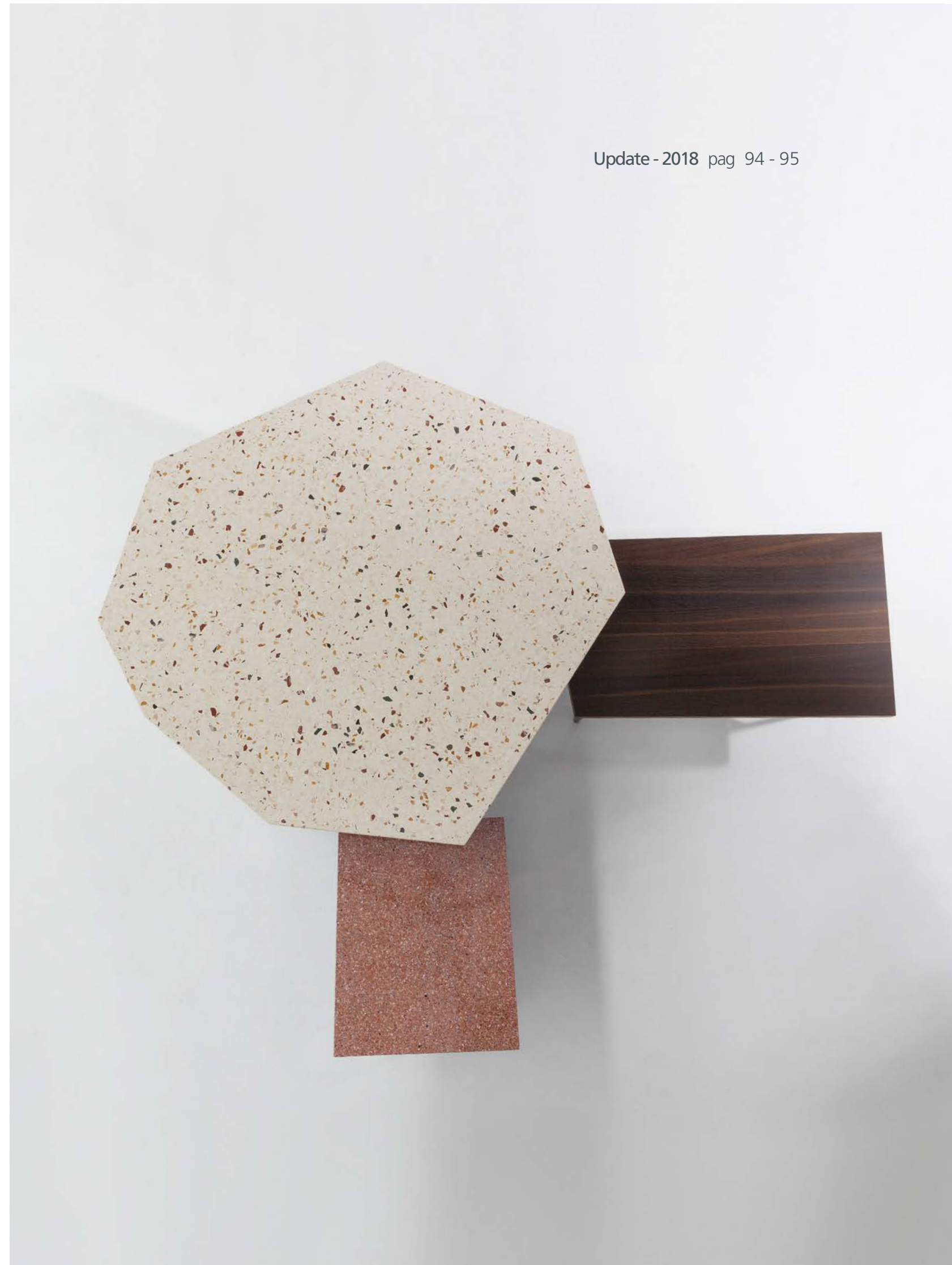

Bardot Laura Cazzaniga e Ilaria Limonta

Update - 2018 pag 96 - 97

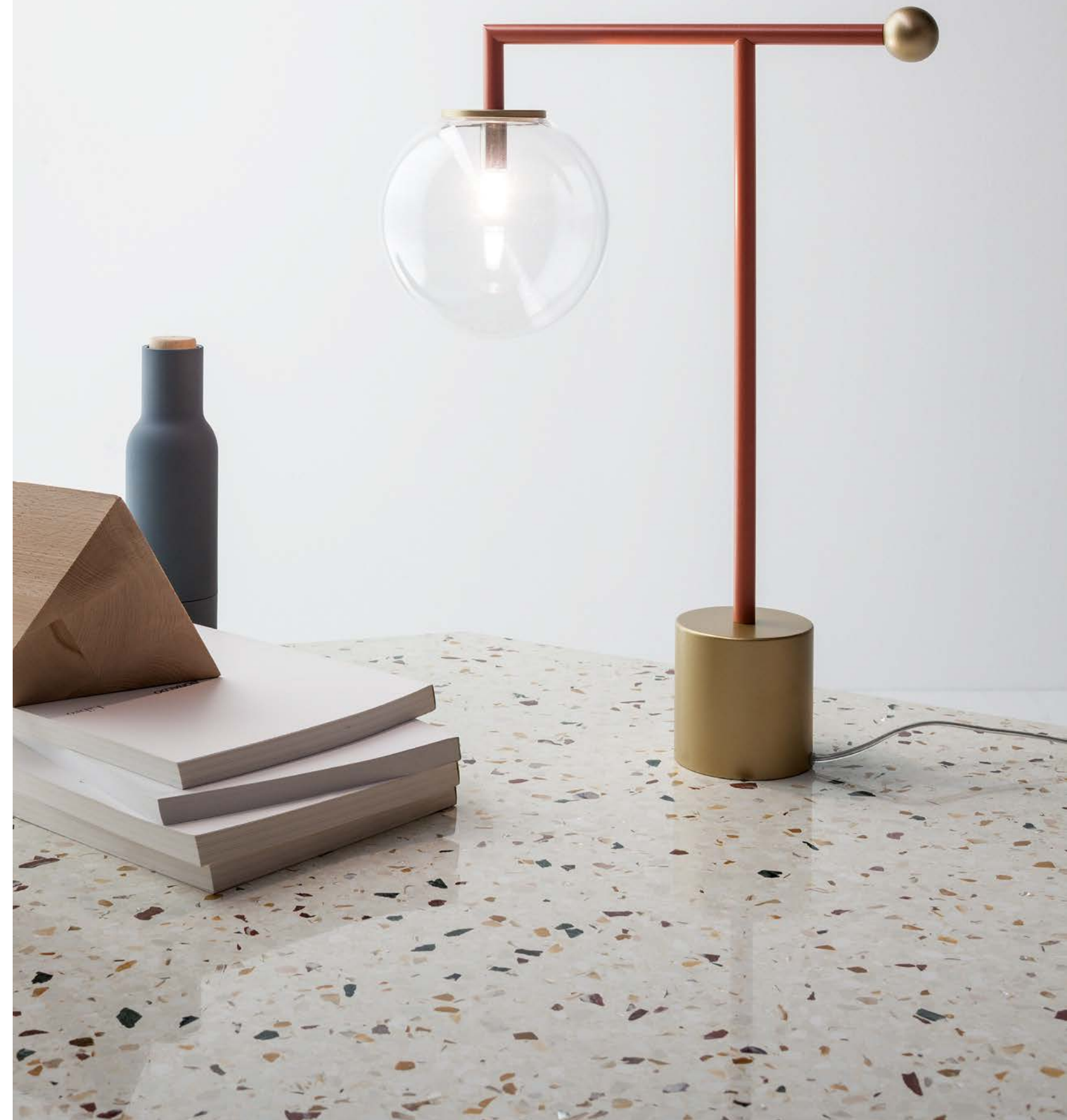



Poltrone / Armchairs

Lock – Alessandro Busana

Lovy armchair bergère – Sergio Bicego

Lovy armchair low – Sergio Bicego

Tirella - Paolo Grasselli

Lovy armchair low Sergio Bicego



Update - 2018 pag 102 - 103



Lovy armchair bergère Sergio Bicego

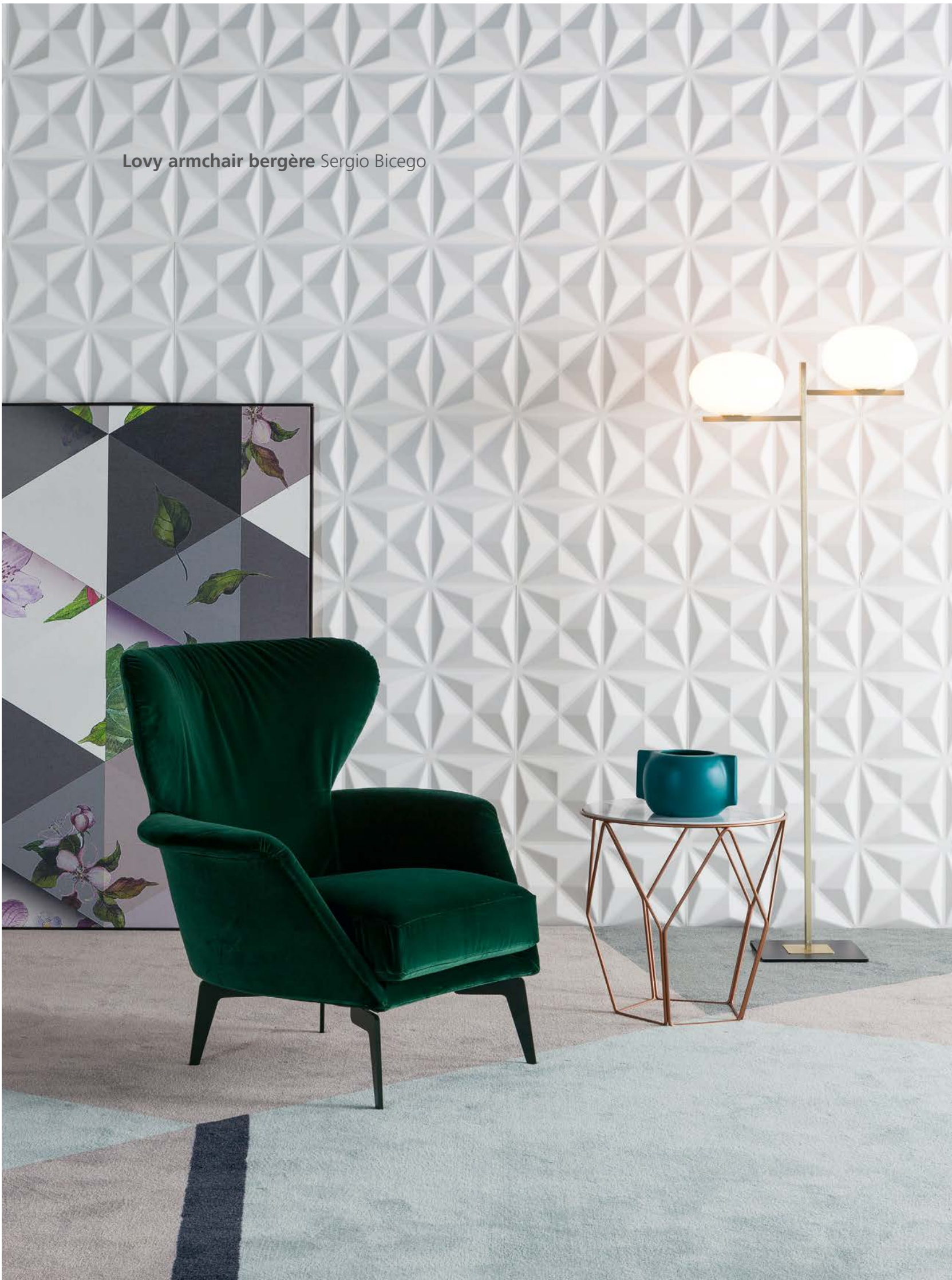

Tirella Paolo Grasselli



Update - 2018 pag 106 - 107

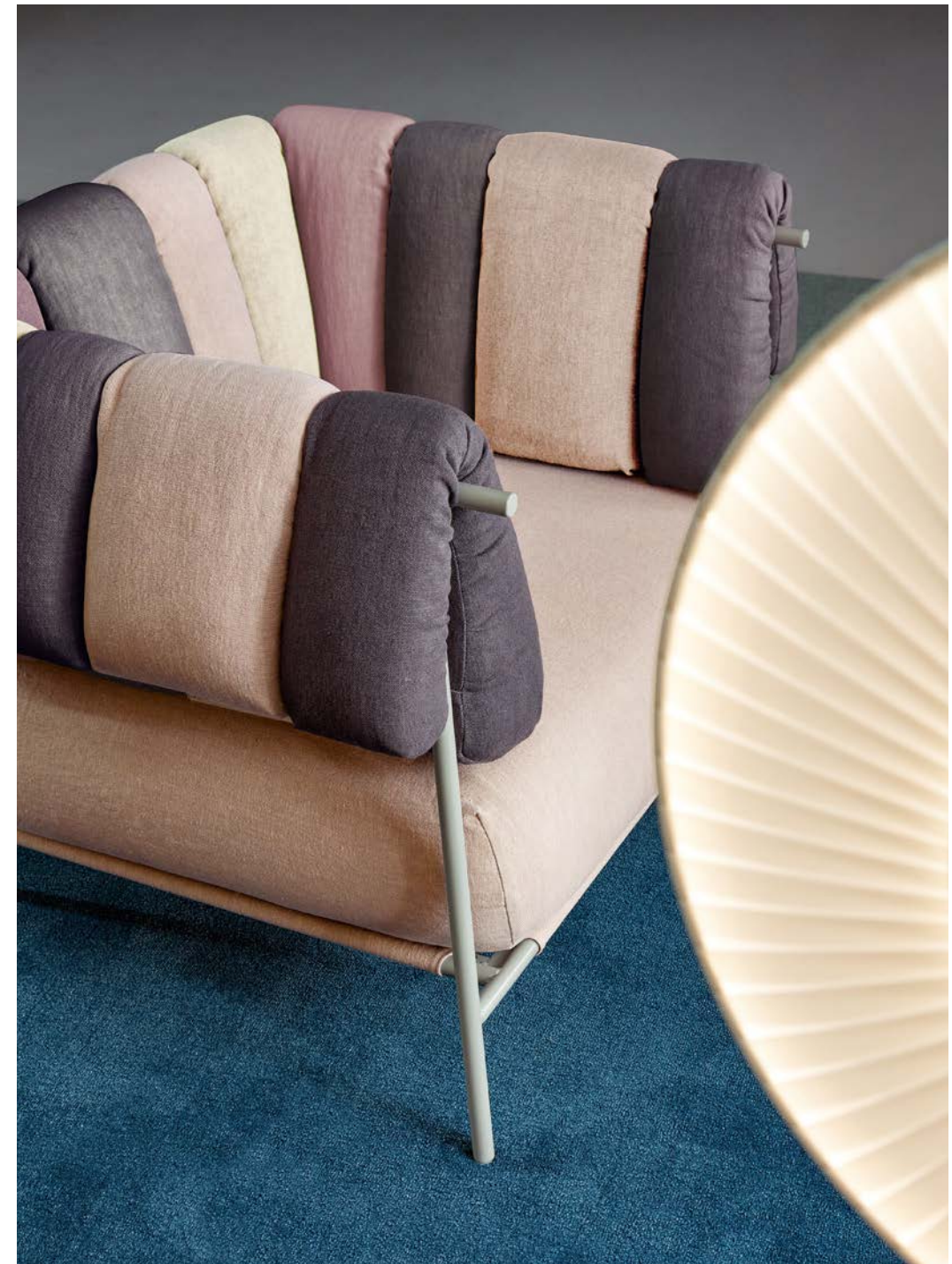



Lock ego Alessandro Busana



Lock soft, Lock Alessandro Busana

Update - 2018 pag 110 - 111



Lock Alessandro Busana



Update - 2018 pag 112 - 113



Divani / Sofas

Arno sofa – Mauro Lipparini

Cortina – Mauro Lipparini

Lovy ego– Sergio Bicego

Lovy hi – Sergio Bicego

Madame C. – Giuseppe Viganò

Panorama – Fabrice Berrux

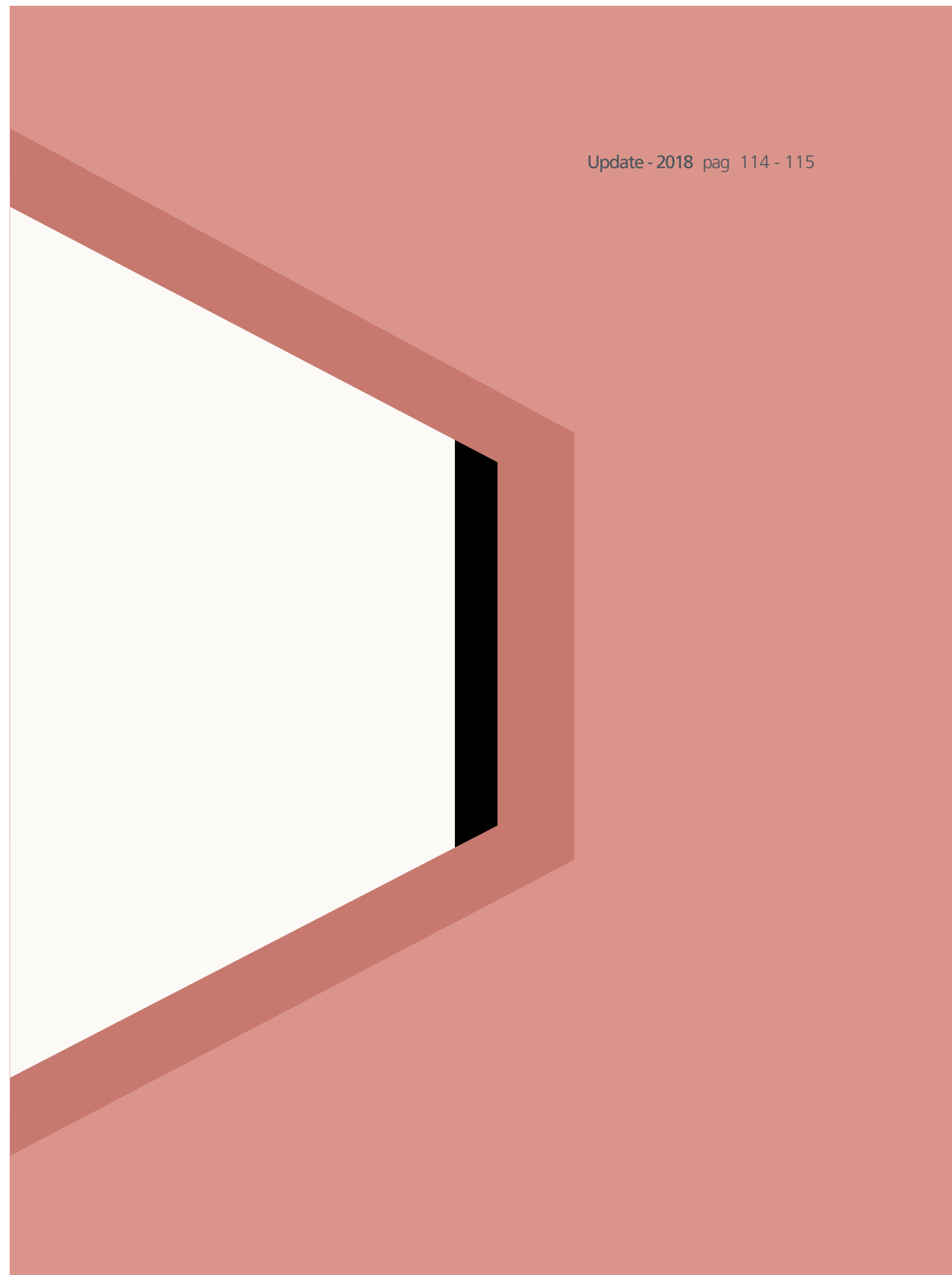



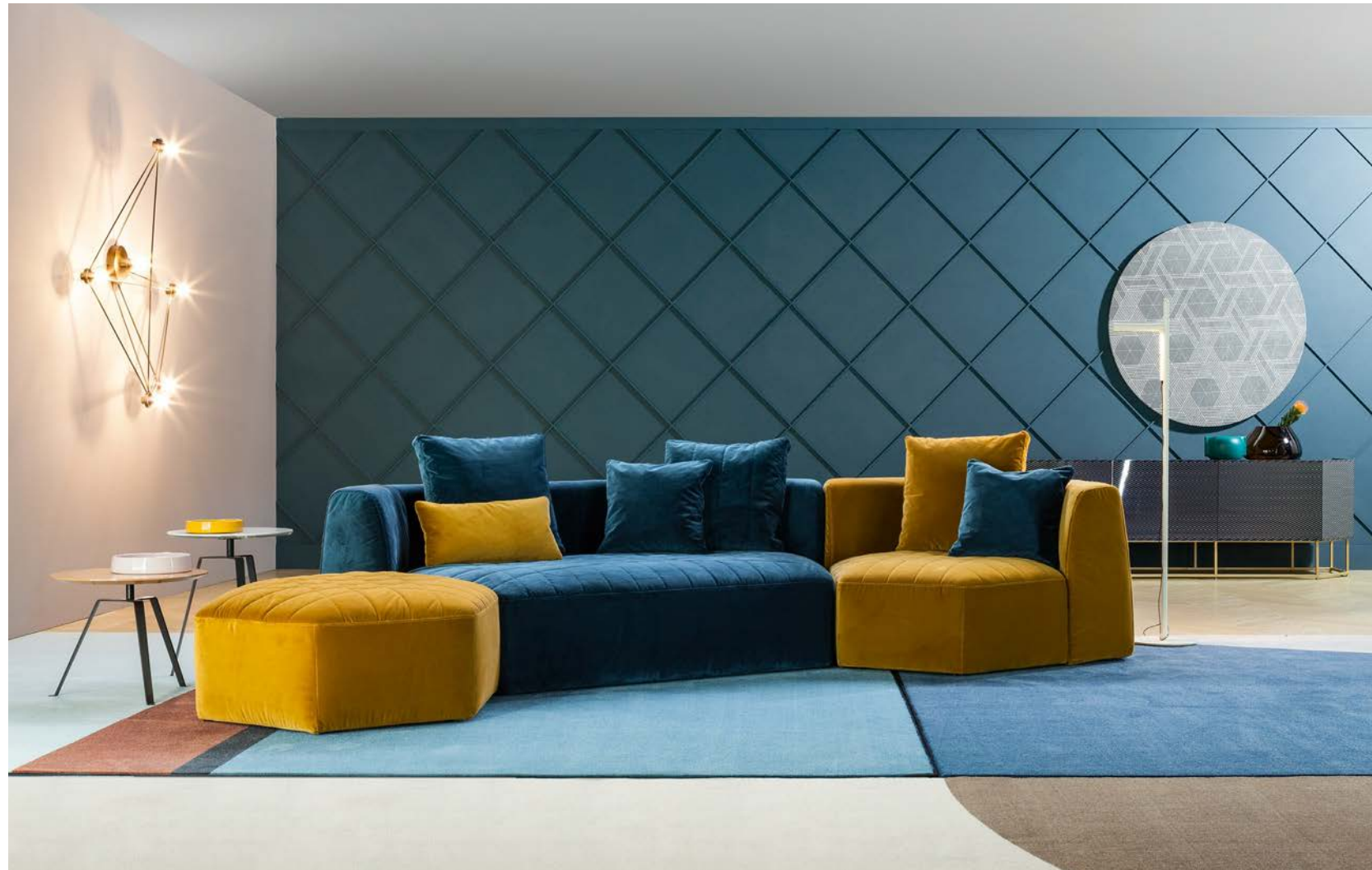



Panorama Fabrice Berrux



Update - 2018 pag 122 - 123





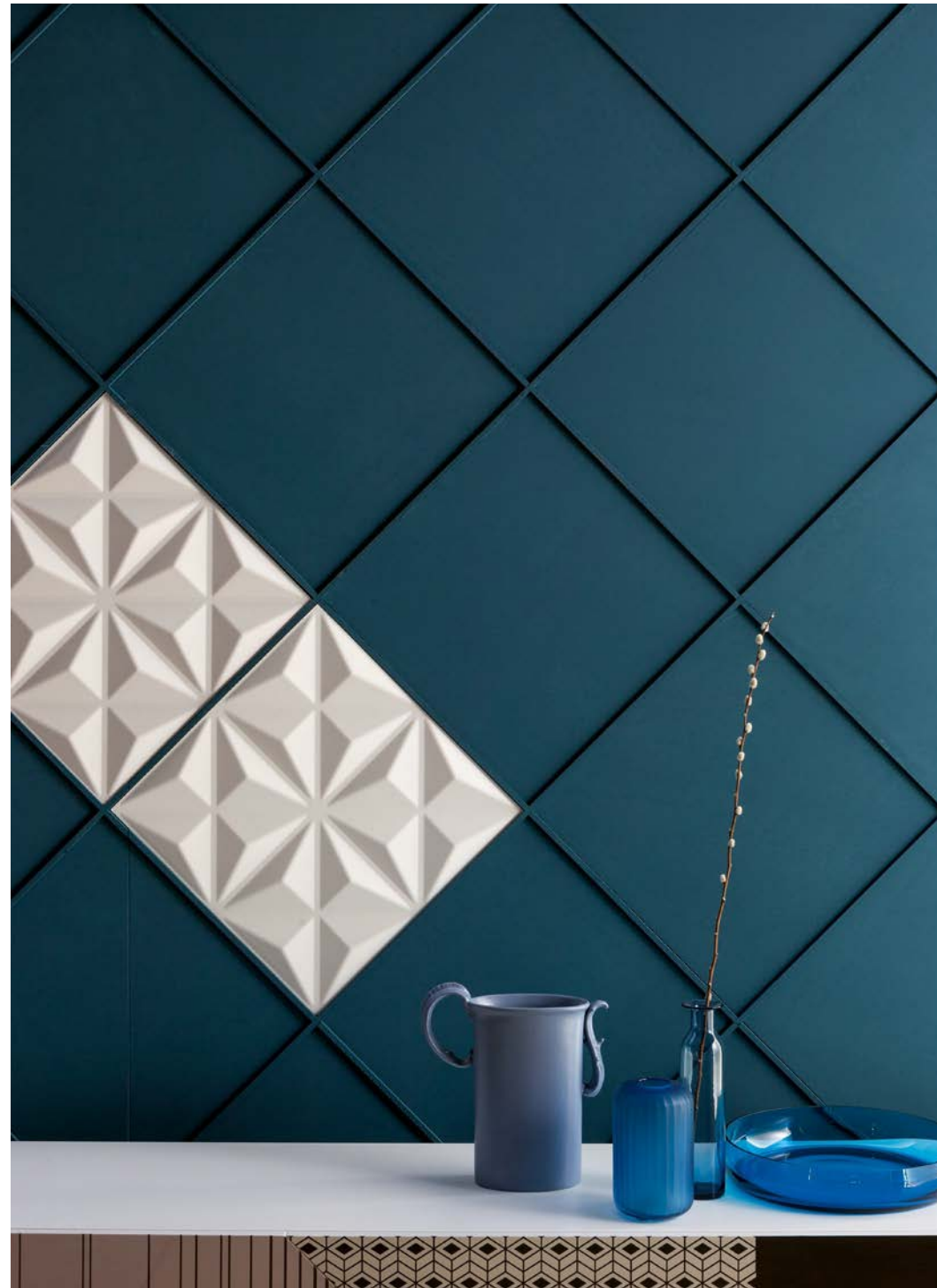



Madame C. Giuseppe Viganò



Update - 2018 pag 130 - 131



Madame C. Giuseppe Viganò



Update - 2018 pag 132 - 133



Arno sofa Mauro Lipparini



Arno sofa Mauro Lipparini

Update - 2018 pag 136 - 137



Lovy hi Sergio Bicego

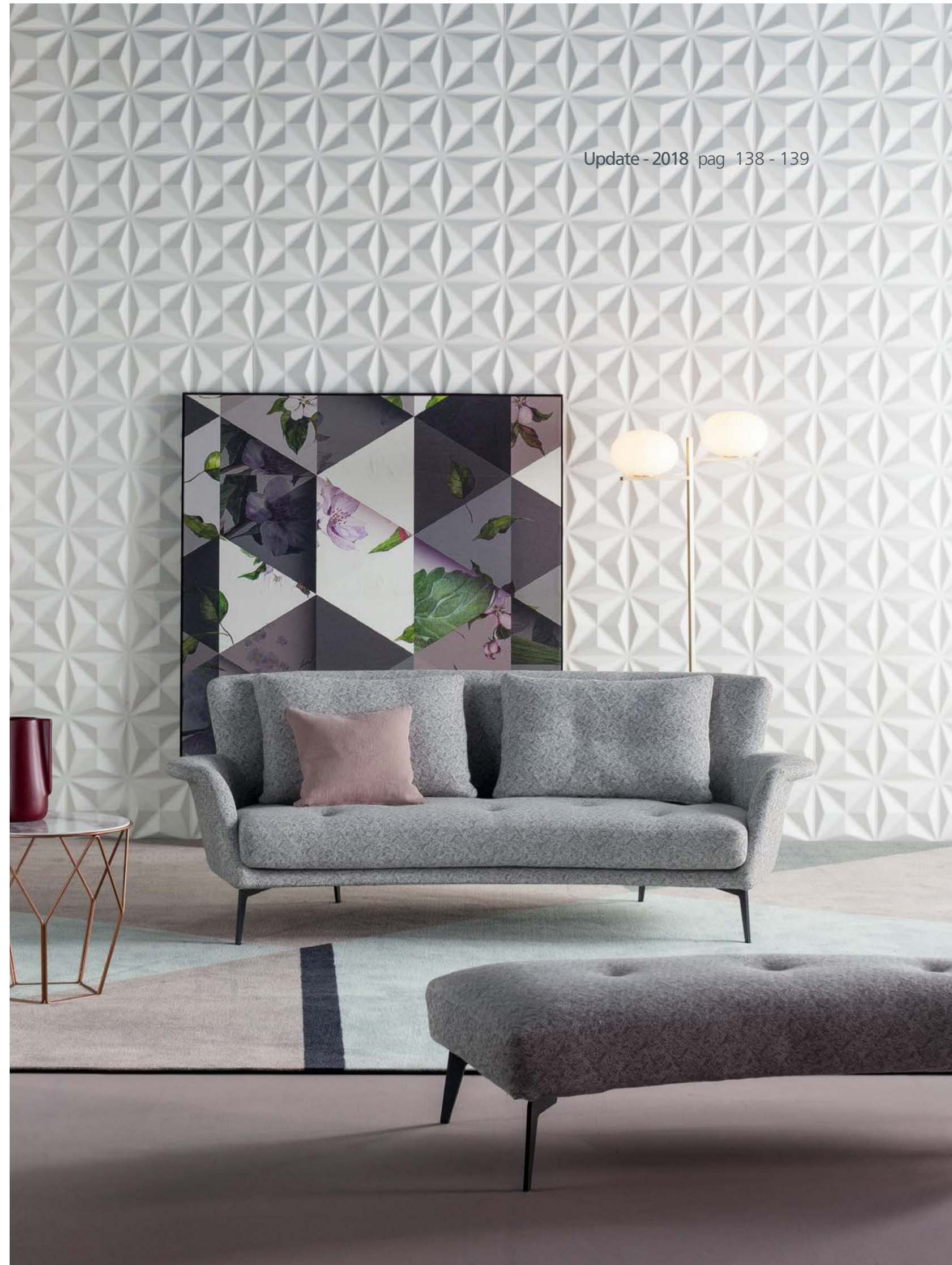

Lovy hi Sergio Bicego



Lovy ego Sergio Bicego



Update - 2018 pag 142 - 143



Cortina Mauro Lipparini



Update - 2018 pag 144 - 145









Letti / Beds

Kenobi – Mauro Lipparini

Youniverse – Mauro Lipparini

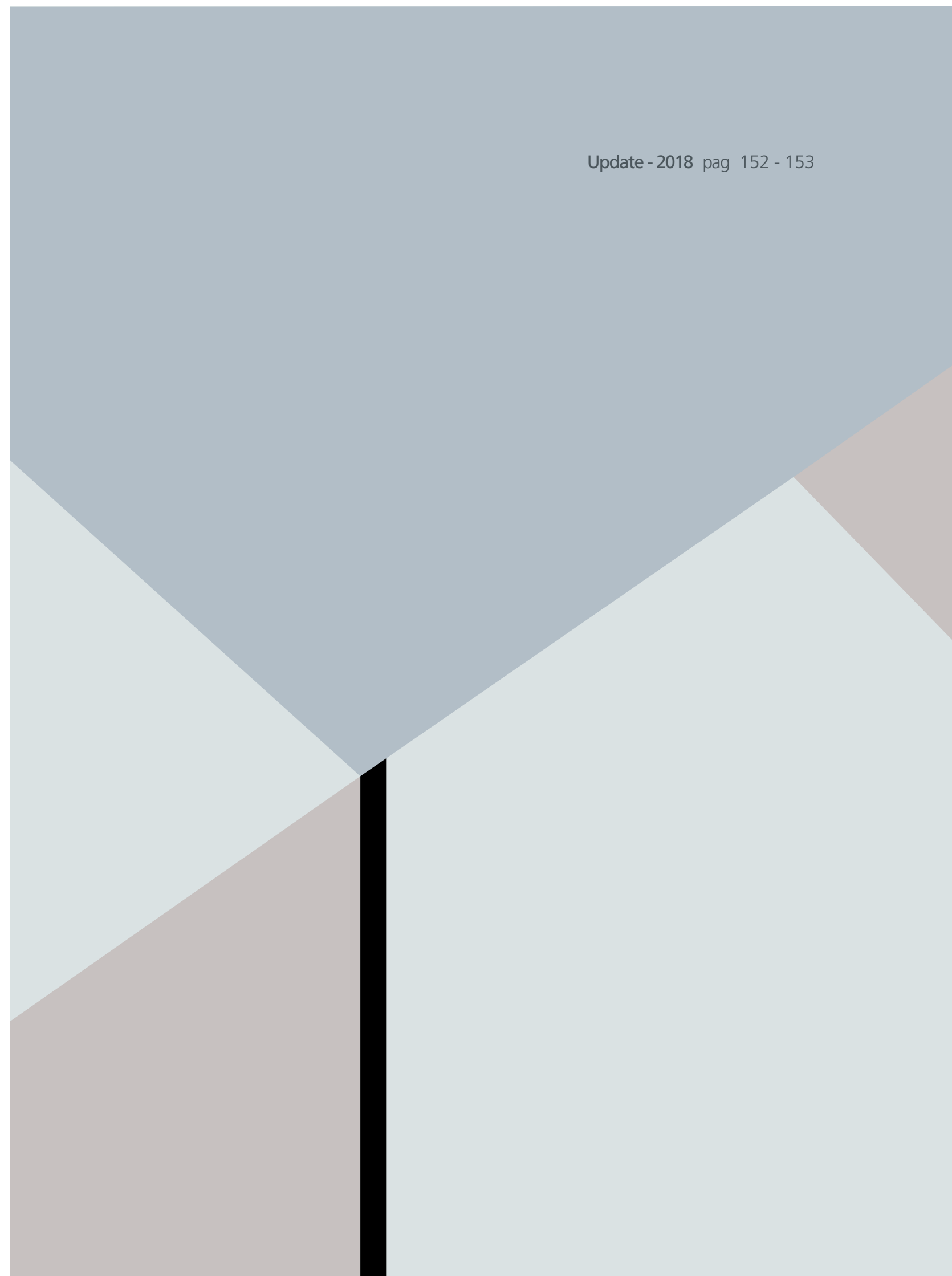

Youniverse Mauro Lipparini



Update - 2018 pag 154 - 155







Kenobi Mauro Lipparini

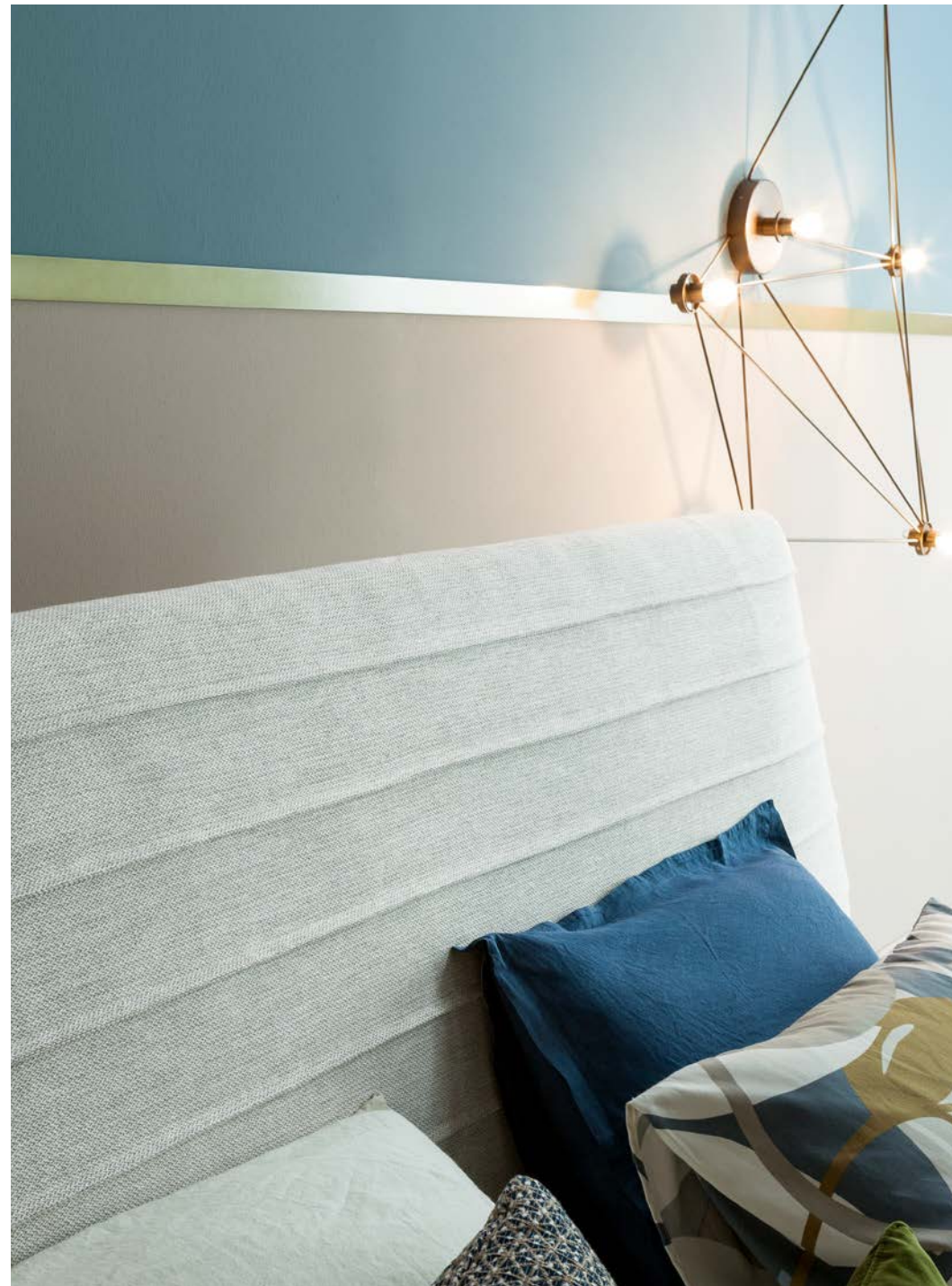

Update - 2018 pag 160 - 161









Arno sofa	p.196	Lock, Lock ego, Lock soft	p.192	Pil, Pil up, Miss Pil,	
Art	p.174	Lovy armchair low,		Miss Pil up, Pil too	p.171
Bardot	p.184	Lovy armchair bergère	p.193	Pangea	p.170
Benedetta, Benedetta up	p.168	Lovy, Lovy ego,		Prora	p.178
Blues	p.169	Lovy low, Lovy hi	p.197	Stone	p.172
Cabinet de Curiosité	p.185	Madame C.	p.200	Tangle	p.180
Cortina	p.198	Movie	p.188	Tirella	p.195
Day	p.186	Note Sideboard	p.189	Truly	p.182
Fragment	p.187	Outline	p.190	Why Not, Why Not up,	
Giuseppina	p.169	Panorama	p.202	Miss Why Not	p.173
Idole	p.170	Panorama armchair	p.194	Youniverse	p.205
Kenobi	p.204				

BENEDETTA, BENEDETTA UP



①

RIVESTIMENTO / UPHOLSTERY / BEZUG / REVÊTEMENT

pelle ecopelle tessuto	leather eco-leather fabric	Leder Kunstleder Stoff	cuir souple éco-cuir tissu
------------------------------	----------------------------------	------------------------------	----------------------------------

②

FINITURA GAMBE/LEGS FINISH/BEINE AUSFÜHRUNG/FINITION PIEDS

LEGNO MASSELLO			METALLO FINITURA		
1. frassino spazzolato naturale	2. frassino spazzolato grigio	3. frassino color noce	4. rame opaco	5. ottone opaco	
METALLO VERNICIATO OPAQUE			6. bianco	7. nero	8. grigio antracite
9. tortora	10. marrone	11. azzurro artico	12. mattone	13. bordeaux	14. racing green
			15. coffee brown		

SOLID WOOD
1. ash polished natural
2. ash polished grey
3. walnut painted ash

MASSIVHOLZ
1. Esche Natur poliert
2. Esche Grau poliert
3. Esche nussbaumfarbig lackiert

BOIS MASSIF
1. frêne naturel brossé
2. frêne gris brossé
3. frêne teinté noyer

METAL FINISH
4. mat copper
5. mat brass

METALL AUSFÜHRUNG
4. Kupfer matt
5. Messing matt

FINITION MÉTAL
4. cuivre opaque
5. laiton opaque

MAT PAINTED METAL
6. white
7. black
8. anthracite grey
9. dove grey
10. brown
11. arctic blue
12. brick red
13. bordeaux
14. racing green
15. coffee brown

METALL MAT LACKIERT
6. Weiss
7. Schwarz
8. Anthrazitgrau
9. Taubengrau
10. Brown
11. Arktisch blau
12. Ziegelrot
13. Bordeaux
14. Racing Green
15. Coffee Brown

MÉTAL VERNI OPAQUE
6. blanc
7. noir
8. gris anthracite
9. gris tourterelle
10. marron
11. bleu artique
12. brique
13. bordeaux
14. racing green
15. coffee brown

DIMENSIONI / DIMENSIONS / GRÖSSEN / DIMENSIONS

BENEDETTA

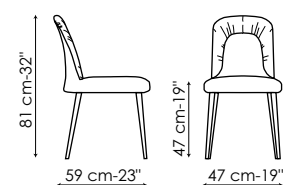

BENEDETTA UP

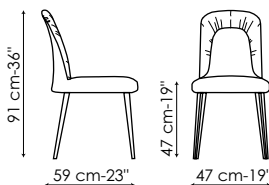

pag. 65:
BENEDETTA UP – tessuto MC08, fascia schienale MC06, gambe bordeaux / fabric MC08, backrest band MC06, bordeaux legs / tissu MC08, bordure du dossier MC06, pieds bordeaux / Stoff MC08, Rückenlehne Einlage MC06, Bordeaux Beine

pag. 65:
BENEDETTA UP – tessuto MC29, fascia schienale MC25, gambe grigio antracite / fabric MC29, backrest band MC25, anthracite grey legs / tissu MC29, bordure du dossier MC25, pieds gris anthracite / Stoff MC29, Rückenlehne Einlage MC25, Anthrazitgrau Beine

pag. 66, 67:
BENEDETTA UP – pelle Capri L09, fascia schienale MC28, gambe nere / Capri leather L09, backrest band MC28, black legs / cuir souple Capri L09, bordure du dossier MC28, pieds noirs / Leder Capri L09, Rückenlehne Einlage MC28, Schwarz Beine

pag. 67:
BENEDETTA – pelle Capri L51, gambe grigio antracite / Capri leather L51, anthracite grey legs / cuir souple Capri L51, pieds gris anthracite / Leder Capri L51, Anthrazitgrau Beine

pag. 67:
BENEDETTA UP – tessuto MC29, gambe nere / fabric MC29, black legs / tissu MC29, pieds noirs / Stoff MC29, Schwarz Beine

BLUES



①

FINITURA / FINISH / AUSFÜHRUNG / FINITION

POLIPROPILENE OPAQUE

1. bianco	2. grigio chiaro	3. grigio antracite	4. tortora	5. rosso mattone	6. senape
-----------	------------------	---------------------	------------	------------------	-----------

MAT POLYPROPYLENE
1. white
2. light grey
3. anthracite grey
4. dove grey
5. brick red
6. mustard yellow

POLYPROPYLEN MATT
1. Weiss
2. Hellgrau
3. Anthrazitgrau
4. Taubengrau
5. Ziegelrot
6. Seuf

POLYPROPYLÈNE OPAQUE
1. blanc
2. gris clair
3. gris anthracite
4. gris tourterelle
5. brique
6. moutarde

DIMENSIONI / DIMENSIONS / GRÖßEN / DIMENSIONS

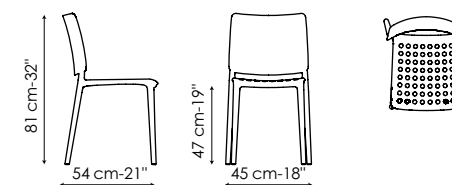

pag. 68, 69:
tortora, rosso mattone, grigio antracite, grigio chiaro, bianco, senape / dove grey, brick red, anthracite grey, light grey, white, mustard yellow / gris tourterelle, brique, gris anthracite, gris clair, blanc, moutarde / Taubengrau, Ziegelrot, Anthrazitgrau, Hellgrau, Weiss, Senf

GIUSEPPINA



①

FINITURA / FINISH / AUSFÜHRUNG / FINITION

POLIPROPILENE OPAQUE

1. bianco	2. grigio antracite	3. tortora	4. rosso mattone	5. senape
-----------	---------------------	------------	------------------	-----------

MAT POLYPROPYLENE
1. white
2. anthracite grey
3. dove grey
4. brick red
5. mustard yellow

POLYPROPYLEN MATT
1. Weiss
2. Anthrazitgrau
3. Taubengrau
4. Ziegelrot
5. Seuf

POLYPROPYLÈNE OPAQUE
1. blanc
2. gris anthracite
3. gris tourterelle
4. brique
5. moutarde

DIMENSIONI / DIMENSIONS / GRÖßEN / DIMENSIONS

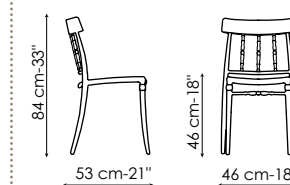

pag. 74-75:
grigio antracite, bianco, tortora, rosso mattone, senape / anthracite grey, white, dove grey, brick red, mustard yellow / gris anthracite, blanc, gris tourterelle, brique, moutarde / Anthrazitgrau, Weiss, Taubengrau, Ziegelrot, Senf

IDOLE



①
FINITURA / FINISH / AUSFÜHRUNG / FINITION

POLIPROPILENE OPACO



MAT POLYPROPYLENE

1. white
2. anthracite grey
3. dove grey
4. brick red
5. olive green

POLYPROPYLEN MATT

1. Weiss
2. Anthrazitgrau
3. Taubengrau
4. Ziegelrot
5. Olivgruen

POLYPROPYLENE OPAQUE

1. blanc
2. gris anthracite
3. gris tourterelle
4. brique
5. vert olive

DIMENSIONI / DIMENSIONS / GRÖßEN / DIMENSIONS

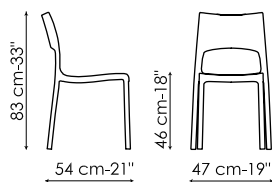

pag. 70-71:
grigio antracite, rosso mattone, bianco, tortora, verde oliva / anthracite grey, brick red, white, dove grey, olive green / gris anthracite, brique, blanc, gris tourterelle, vert olive / Anthrazitgrau, Ziegelrot, Weiss, Taubengrau, Olivgrün

PANGEA



①
FINITURA / FINISH / AUSFÜHRUNG / FINITION

POLIPROPILENE OPACO



MAT POLYPROPYLENE

1. white
2. anthracite grey
3. dove grey
4. brick red
5. olive green

POLYPROPYLEN MATT

1. Weiss
2. Anthrazitgrau
3. Taubengrau
4. Ziegelrot
5. Olivgruen

POLYPROPYLENE OPAQUE

1. blanc
2. gris anthracite
3. gris tourterelle
4. brique
5. vert olive

DIMENSIONI / DIMENSIONS / GRÖßEN / DIMENSIONS

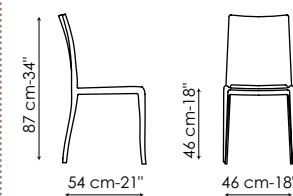

pag. 72-73:
grigio antracite, tortora, verde oliva, bianco, rosso mattone / anthracite grey, dove grey, olive green, white, brick red / gris anthracite, gris tourterelle, vert olive, blanc, brique / Anthrazitgrau, Taubengrau, Olivgrün, Weiss, Ziegelrot

PIL, PIL UP, MISS PIL, MISS PIL UP, PIL TOO



①
RIVESTIMENTO / UPHOLSTERY / BEZUG / REVÊTEMENT

pelle
ecopelle
tessuto

leather
eco-leather
fabric

Leder
Kunstleder
Stoff

cuir souple
éco-cuir
tissu

②
FINITURA GAMBE / LEGS FINISH / BEINE AUSFÜHRUNG / FINITION PIEDS

METALLO FINITURA

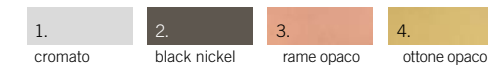

METAL FINISH

1. chromed
2. black nickel
3. mat copper
4. mat brass

METALL AUSFÜHRUNG

1. Verchromt
2. Schwarz vernickelt
3. Kupfer matt
4. Messing matt

FINITION MÉTAL

1. chromé
2. noir nickel
3. cuivre opaque
4. laiton opaque

METALLO VERNICIATO OPACO

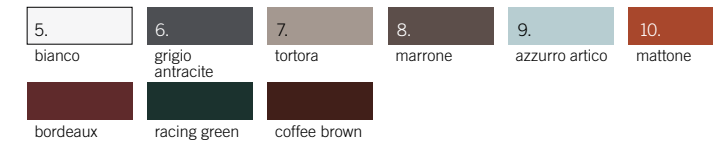

MAT PAINTED METAL

5. white
6. anthracite grey
7. dove grey
8. brown
9. arctic blue
10. brick red
11. bordeaux
12. racing green
13. coffee brown

METALL MAT LACKIERT

5. Weiss
6. Anthrazitgrau
7. Taubengrau
8. Brown
9. Arktisch blau
10. Ziegelrot
11. Bordeaux
12. Racing Green
13. Coffee Brown

MÉTAL VERNI OPAQUE

5. blanc
6. gris anthracite
7. gris tourterelle
8. marron
9. bleu arctique
10. brique
11. bordeaux
12. racing green
13. coffee brown

DIMENSIONI / DIMENSIONS / GRÖßEN / DIMENSIONS

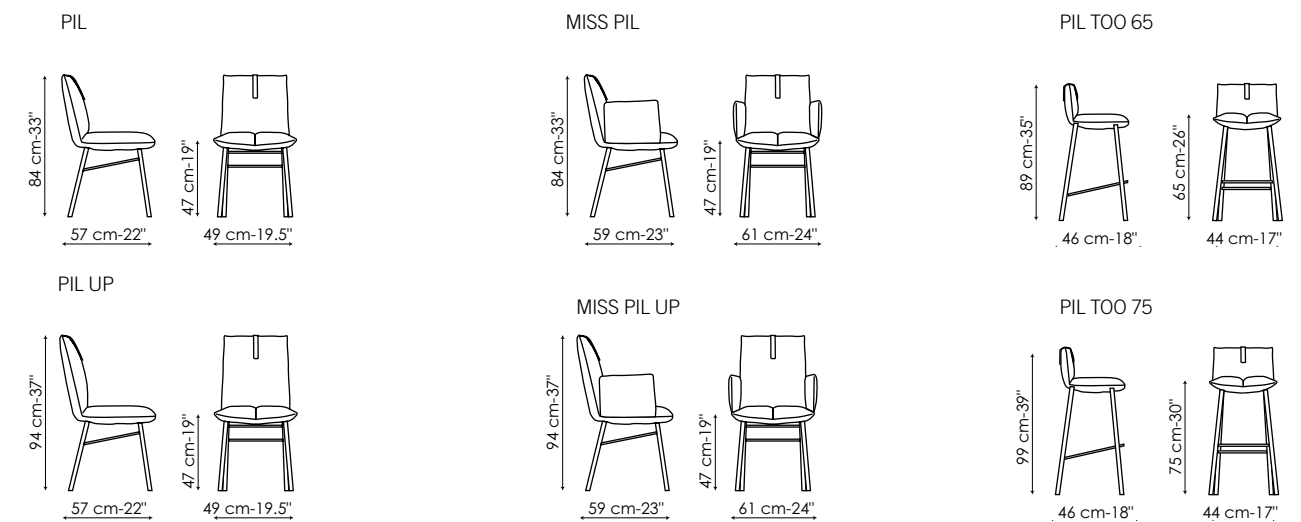

pag. 56, 57:
PIL – tessuto 97S, gambe grigio antracite / fabric 97S, anthracite grey legs / tissu 97S, pieds gris anthracite / Stoff 97S, Anthrazitgrau Beine

pag. 58:
PIL UP – tessuto 97C, gambe tortora / fabric 97C, dove grey legs / tissu 97C, pieds gris tourterelle / Stoff 97C, Taubengrau Beine

pag. 58:
PIL – tessuto 92T, gambe marrone / fabric 92T, brown legs / tissu 92T, pieds marrons / Stoff 92T, Braun Beine

pag. 59:
PIL TOO – tessuto 97J, gambe amaranto / fabric 97J, amaranth legs / tissu 97J, pieds amarante / Stoff 97J, Amaranth Beine

pag. 59:
MISS PIL – tessuto 97S, gambe grigio antracite / fabric 97S, anthracite grey legs / tissu 97S, pieds gris anthracite / Stoff 97S, Anthrazitgrau Beine



1

RIVESTIMENTO / UPHOLSTERY / BEZUG / REVÊTEMENT

pelle ecopelle	leather eco-leather	Leder Kunstleder	cuir souple éco-cuir
-------------------	------------------------	---------------------	-------------------------

2

FINITURA GAMBE/LEGS FINISH/BEINE AUSFÜHRUNG/FINITION PIEDS

LEGNO MASSELLO

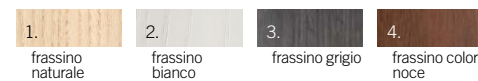

METALLO VERNICIATO OPACO



METALLO FINITURA

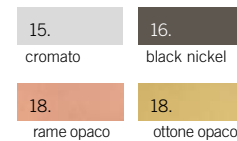

SOLID WOOD

1. ash natural
2. ash white
3. ash grey
4. walnut painted ash

MAT PAINTED METAL

5. white
6. anthracite grey
7. dove grey
8. brown
9. arctic blue
10. brick red
11. bordeaux
12. racing green
13. coffee brown
14. silver

METAL FINISH

15. chromed
16. black nickel
17. mat copper
18. mat brass

MASSIVHOLZ

1. Esche Natur
2. Esche Weiss
3. Esche Grau
4. Esche nussbaumfarbig lackiert

METALL MAT LACKIERT

5. Weiss
6. Anthrazitgrau
7. Taubengrau
8. Brown
9. Arktisch blau
10. Ziegelrot
11. Bordeaux
12. Racing Green
13. Coffee Brown
14. Silber

METALL AUSFÜHRUNG

15. Verchromt
16. Schwarz vernickelt
17. Kupfer matt
18. Messing matt

BOIS MASSIF

1. frêne naturel
2. frêne blanc
3. frêne gris
4. frêne teinté noyer

MÉTAL VERNI OPAQUE

5. blanc
6. gris anthracite
7. gris tourterelle
8. marron
9. bleu artique
10. brique
11. bordeaux
12. racing green
13. coffee brown
14. argent

FINITION MÉTAL

15. chromé
16. noir nickel
17. cuivre opaque
18. laiton opaque

DIMENSIONI / DIMENSIONS / GRÖSSEN / DIMENSIONS

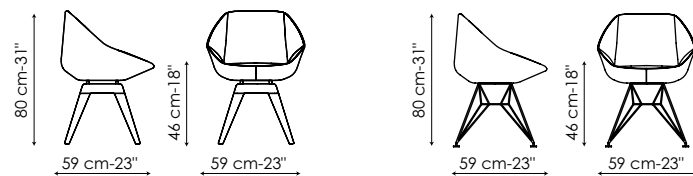

pag. 48, 49: pelle Capri L44, base in metallo racing green / Capri leather L44, racing green metal base / cuir souple Capri L44, base en métal racing green / Capri Leder L44, Racing Green Metall Basis

pag. 49, 54: pelle Capri L41, base in metallo argento opaco / Capri leather L41, mat silver metal base / cuir souple Capri L41, base en métal argent opaque / Capri Leder L41, Silber matt Metall Basis

pag. 50, 51, 55: pelle Capri L09, base in frassino spazzolato grigio / Capri leather L09, grey polished ash base / cuir souple Capri L09, base en frêne gris brossé / Capri Leder L09, Esche Grau polierte Basis

3 PERNO BASE GIREVOLE / SWIVEL BASE PIVOT / SCHWENKEN DREHBARE BASIS / PIVOT BASE PIVOTANTE

METALLO VERNICIATO OPACO

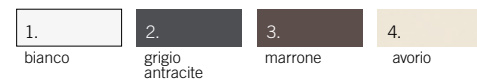

MAT PAINTED METAL

1. white
2. anthracite grey
3. brown
4. ivory

METALL MAT LACKIERT

1. Weiss
2. Anthrazitgrau
3. Braun
4. Elfenbeinweiss

MÉTAL VERNI OPAQUE

1. blanc
2. gris anthracite
3. marron
4. ivoire

STONE GIREVOLE / SWIVEL / DREHBAREN / PIVOTANTE

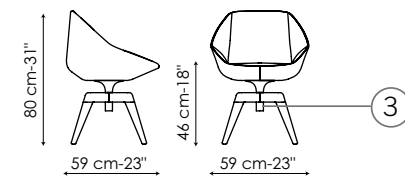

pag. 52, 53, 54: pelle Capri L30, base girevole in frassino color noce, perno marrone / Capri leather L30, walnut-painted ash swivel base, brown pivot / cuir souple Capri L30, base pivotante en frêne teinté noyer, pivot marron / Capri Leder L30, Esche nussbaumfarbig lackiert, drehbare Basis, Braun Schwenken

pag. 55: pelle Capri L50, base in metallo grigio antracite / Capri leather L50, anthracite grey metal base / cuir souple Capri L50, base en métal gris anthracite / Capri Leder L50, Anthrazitgrau Metall Basis



1

RIVESTIMENTO / UPHOLSTERY / BEZUG / REVÊTEMENT

(disponibile liscio o trapuntato) pelle ecopelle tessuto	(available plain or quilted) leather eco-leather fabric	(verfügbar glatt oder gesteppt) Leder Kunstleder Stoff	(disponible lisse ou matelassé) cuir souple éco-cuir tissu
---	--	---	---

2

FINITURA GAMBE/LEGS FINISH/BEINE AUSFÜHRUNG/FINITION PIEDS

METALLO FINITURA

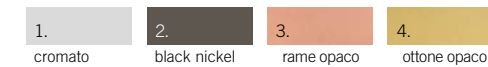

METALLO VERNICIATO OPACO

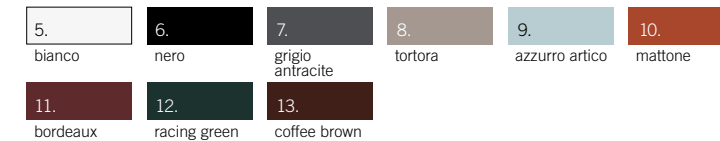

METAL FINISH

1. chromed
2. black nickel
3. mat copper
4. mat brass

MAT PAINTED METAL

5. white
6. black
7. anthracite grey
8. dove grey
9. arctic blue
10. brick red
11. bordeaux
12. racing green
13. coffee brown

METALL AUSFÜHRUNG

1. Verchromt
2. Schwarz vernickelt
3. Kupfer matt
4. Messing matt

METALL MAT LACKIERT

5. Weiss
6. Schwarz
7. Anthrazitgrau
8. Taubengrau
9. Arktisch blau
10. Ziegelrot
11. Bordeaux
12. Racing Green
13. Coffee Brown

FINITION MÉTAL

1. chromé
2. noir nickel
3. cuivre opaque
4. laiton opaque

MÉTAL VERNI OPAQUE

5. blanc
6. noir
7. gris anthracite
8. gris tourterelle
9. bleu artique
10. brique
11. bordeaux
12. racing green
13. coffee brown

DIMENSIONI / DIMENSIONS / GRÖSSEN / DIMENSIONS

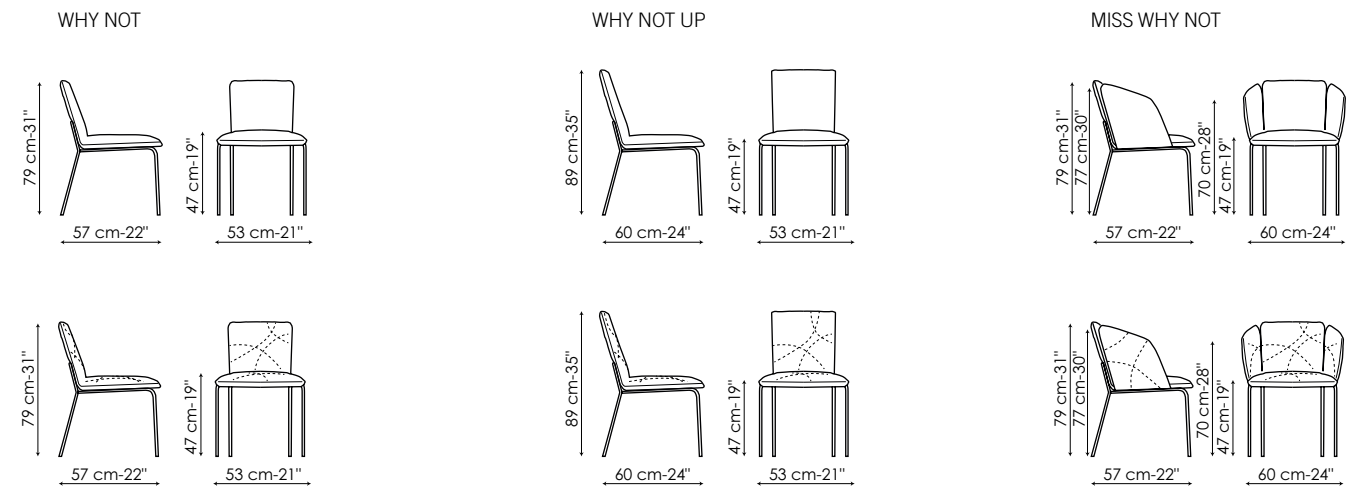

pag. 60, 61: MISS WHY NOT – tessuto trapuntato 97T, gambe nere / quilted fabric 97T, black legs / tissu matelassé 97T, pieds noirs / gesteppter Stoff 97T, Schwarz Beine

pag. 62, 63: WHY NOT UP – tessuto trapuntato MB71, gambe nere / quilted fabric MB71, black legs / tissu matelassé MB71, pieds noirs / gesteppter Stoff MB71, Schwarz Beine



1

FINITURA PIANO / TOP FINISH / PLATTE AUSFÜHRUNG / FINITION PLAN

LACCATO	IMPIALLACCIATO LEGNO	LEGNO CON BORDI NATURALI
1. bianco opaco	2. noce canaletto 3. rovere spazzolato termotrattato 4. rovere spazzolato naturale 5. rovere spazzolato grigio antracite	6. noce americano
LEGNO MASSICCIO	CERAMICA LUCIDA	CERAMICA OPACA
7. noce americano 8. rovere spazzolato naturale 9. rovere spazzolato grigio antracite	10. Calacatta 11. Onice oro 12. grigio Ardesia	
CRISTALLO		
13. trasparente		

LACQUERED 1. mat white	LACKIERT 1. Weiss matt	LAQUÉ 1. blanc opaque
VENEERED WOOD 2. walnut Canaletto 3. heat-treated polished oak 4. natural polished oak 5. anthracite grey polished oak	HOLZ FURNIERT 2. Nussbaum Canaletto 3. Eiche thermo-behandelte poliert 4. Eiche Natur poliert 5. Eiche Anthrazitgrau poliert	BOIS PLAQUÉ 2. noyer Canaletto 3. rouvre brossé traité thermiquement 4. rouvre brossé naturel 5. rouvre brossé gris anthracite
SOLID WOOD 7. American walnut 8. natural polished oak 9. anthracite grey polished oak	MASSIVE TIESCHERPLATTE MIT ECHTHOLZFURNIER 7. Amerikaner Nussbaum 8. Eiche Natur poliert 9. Eiche Anthrazitgrau poliert	BOIS MASSIF 7. noyer américain 8. rouvre brossé naturel 9. rouvre brossé gris anthracite
WOOD WITH NATURAL EDGES 6. American walnut	HOLZ MIT WALDKANTE 6. Amerikaner Nussbaum	BOIS AVEC CONTOUR NATUREL 6. noyer américain
GLOSSY CERAMIC 10. Calacatta 11. Gold onice	GLÄNZED KERAMIK 10. Calacatta 11. Gold onice	CÉRAMIQUE BRILLANTE 10. Calacatta 11. Onice d'or
MAT CERAMIC 12. Ardesia grey	MATT KERAMIK 12. Ardesia Grau	CÉRAMIQUE OPAQUE 12. gris Ardesia
GLASS 13. transparent	GLAS 13. Klarglas	CRISTAL 13. transparent

2

FINITURA BASE / BASE FINISH / BASIS AUSFÜHRUNG / FINITION BASE

METALLO VERNICIATO OPACO	MAT PAINTED METAL	METALL MATT LACKIERT	MÉTAL VERNI OPAQUE
1. bianco 2. grigio antracite 3. bordeaux 4. tortora 5. marrone	1. anthracite grey 2. white 3. bordeaux 4. dove grey 5. brown	1. Anthrazitgrau 2. Weiss 3. Bordeaux 4. Taubengrau 5. Braun	1. gris anthracite 2. blanc 3. bordeaux 4. gris tourterelle 5. marron
METALLO FINITURA	METAL FINISH	METALL AUSFÜHRUNG	FINITION METAL
6. brunito 7. bronzo rame	6. burnished 7. copper bronze	6. Brüniert 7. Kupferbronze	6. bruni 7. bronze cuivré

3

INSERTI BASE / BASE INSERTS / BASIS EINLAGE / INSERTS BASE

STANDARD:
nella stessa finitura della base / in the same finish as the base / im gleichen Ausführung wie die Basis / dans la même finition de la base

OPTIONAL LEGNO	WOOD	HOLZ	BOIS
1. noce canaletto 2. rovere spazzolato termotrattato 3. rovere spazzolato naturale 4. rovere spazzolato grigio antracite 5. noce americano	1. walnut Canaletto 2. heat-treated polished oak 3. natural polished oak 4. anthracite grey polished oak 5. American walnut	1. Nussbaum Canaletto 2. Eiche thermo-behandelte poliert 3. Eiche Natur poliert 4. Eiche Anthrazitgrau poliert 5. Amerikaner Nussbaum	1. noyer Canaletto 2. rouvre brossé traité thermiquement 3. rouvre brossé naturel 4. rouvre brossé gris anthracite 5. noyer américain
CERAMICA LUCIDA	GLOSSY CERAMIC	GLÄNZED KERAMIK	CÉRAMIQUE BRILLANTE
6. Calacatta 7. Onice oro 8. grigio Ardesia	6. Calacatta 7. Gold onice	6. Calacatta 7. Gold onice	6. Calacatta 7. Onice d'or
METALLO VERNICIATO OPACO	MAT CERAMIC	MATT KERAMIK	CÉRAMIQUE OPAQUE
9. bianco 10. grigio antracite 11. bordeaux 12. tortora 13. marrone	8. Ardesia grey	8. Ardesia Grau	8. gris Ardesia
MAT PAINTED METAL	MAT CERAMIC	MATT KERAMIK	CÉRAMIQUE OPAQUE
9. white 10. anthracite grey 11. bordeaux 12. dove grey 13. brown	9. Ardesia grey	9. Weiss 10. Anthrazitgrau 11. Bordeaux 12. Taubengrau 13. Braun	9. blanc 10. gris anthracite 11. bordeaux 12. gris tourterelle 13. marron

DIMENSIONI / DIMENSIONS / GRÖSSEN / DIMENSIONS

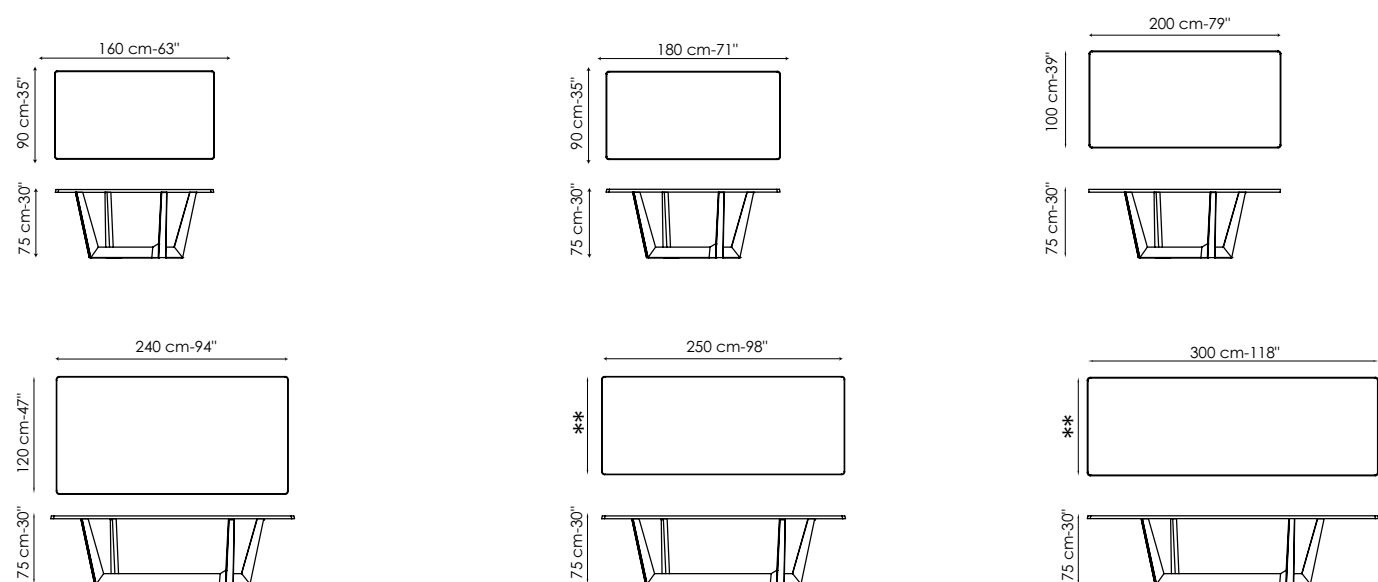

disponibile solo in noce americano massiccio, cristallo, ceramica / available only in solid American walnut, glass, ceramic / Ausführung nur aus massive Amerikaner Nussbaum, Glas, Keramik / disponible seulement en noyer américain massif, cristal, céramique

** 100 cm - 39.4" legno con bordi naturali / wood with natural edges / massive Tiescherplatte mit Echtholz furnier / bois avec contour naturel

** 108 cm - 42.5" laccato, impiallacciato, legno massiccio, cristallo, ceramica / lacquered, veneered wood, solid wood, glass, ceramic / Lackiert, Holz furniert, Massivholz, Glas, Keramik / laqué, bois plaqué, bois massif, cristal, céramique

pag. 12-13: 250 cm - piano e inserti ceramica Calacatta, base grigio antracite / Calacatta ceramic top and inserts, anthracite grey base / plan et inserts en céramique Calacatta, base gris anthracite / Calacatta Keramik Platte und Einlagen, Anthrazitgrau Basis

pag. 14, 15, 17: 250 cm - piano e inserti noce americano, base grigio antracite / American walnut top and inserts, anthracite grey base / plan et inserts en noyer américain, base gris anthracite / Amerikaner Nussbaum Platte und Einlagen, Anthrazitgrau Basis

pag. 18-19: 300x120 cm - piano cristallo trasparente, base grigio antracite, inserti bordeaux / transparent top, anthracite grey base, bordeaux inserts / plan en cristal transparent, base gris anthracite, inserts bordeaux / Klarglas Platte, Anthrazitgrau Basis, Bordeaux Einlagen

pag. 20, 21: 300x120 cm - piano e inserti ceramica grigio ardesia, base grigio antracite / ardesia grey ceramic top and inserts, anthracite grey base / plan et inserts en céramique gris ardesia, base gris anthracite / Ardesia Grau Keramik Platte und Einlagen, Anthrazitgrau Basis

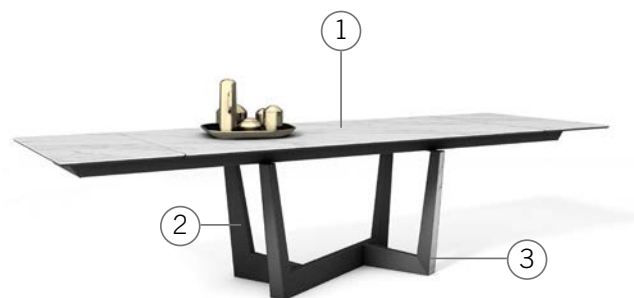

1

FINITURA PIANO E PROLUNGHE / TOP AND LEAVES FINISH / PLATTE UND VERLÄNGERUNGEN AUSFÜHRUNG / FINITION PLAN ET RALLONGES

LACCATO

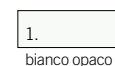

1. bianco opaco

IMPIALLACCIATO LEGNO

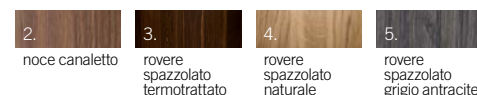

2. noce canaletto
3. rovere spazzolato termotrattato
4. rovere spazzolato naturale
5. rovere spazzolato grigio antracite

CRISTALLO/LEGNO LACCATO



6. acidato nero/laccato nero opaco*
7. acidato grigio antracite/laccato grigio antracite opaco*
8. extrachiario acidato bianco/legno laccato bianco opaco*

CERAMICA LUCIDA

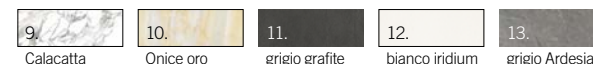

9. Calacatta
10. Onice oro
11. grigio grafite
12. bianco iridium
13. grigio Ardesia

CERAMICA OPACA

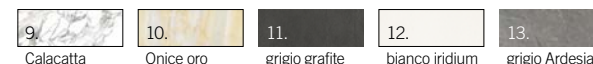

11. grigio grafite
12. bianco iridium
13. grigio Ardesia

* prolunga disponibile anche in cristallo

LACQUERED

1. mat white
VENEERED WOOD
2. walnut Canaletto
3. heat-treated polished oak
4. natural polished oak
5. anthracite grey polished oak

GLASS/LACQUERED WOOD

6. acid-treated black/laquered mat black*
7. acid-treated anthracite grey/laquered mat anthracite grey*
8. extra-light acid treated white/laquered mat white*

GLOSSY CERAMIC

9. Calacatta
10. Gold onice

MAT CERAMIC

11. graphite grey
12. iridium white
13. Ardesia grey

* rallonge disponible aussi en cristal

LACKIERT

1. Weiss matt
HOLZ FURNIERT
2. Nussbaum Canaletto
3. Eiche thermo-behandelte poliert
4. Eiche Natur poliert
5. Eiche Anthrazitgrau poliert

GLAS/LACKIERTEM HOLZ

6. geätztes Schwarz/Schwarz matt lackiert*
7. geätztes Anthrazitgrau/Anthrazitgrau matt lackiert*
8. geätztes extra-hell Weiss/Weiss matt lackiert*

GLÄNZED KERAMIK

9. Calacatta
10. Gold onice

MATT KERAMIK

11. Graphitgrau
12. Iridium Weiss
13. Ardesia Grau

* Verlängerung verfügbar auch auf Glas

LAQUÉ

1. blanc opaque
BOIS PLAQUÉ
2. noyer Canaletto
3. rouvre brossé traité thermiquement
4. rouvre brossé naturel
5. rouvre brossé gris anthracite

CRISTAL/BOIS LAQUÉ

6. traité à l'acide noir/laqué noir opaque*
7. traité à l'acide gris anthracite/laqué gris anthracite opaque*
8. extra-clair traité à l'acide blanc/laqué blanc opaque*

CÉRAMIQUE BRILLANTE

9. Calacatta
10. Onice d'or

CÉRAMIQUE OPAQUE

11. gris graphite
12. blanc iridium
13. gris Ardesia

* rallonge disponible aussi en cristal

2

FINITURA BASE / BASE FINISH / BASIS AUSFÜHRUNG / FINITION BASE

METALLO VERNICIATO OPACO



1. bianco
2. grigio antracite
3. bordeaux
4. tortora
5. marrone

METALLO FINITURA



6. brunito
7. bronzo rame

MAT PAINTED METAL

1. anthracite grey
2. white
3. bordeaux
4. dove grey
5. brown

METAL FINISH

6. brunito
7. copper bronze

METALL MATT LACKIERT

1. Anthrazitgrau
2. Weiss
3. Bordeaux
4. Taubengrau
5. Braun

METALL AUSFÜHRUNG

6. Brüniert
7. Kupferbronze

MÉTAL VERNI OPAQUE

1. gris anthracite
2. blanc
3. bordeaux
4. gris tourterelle
5. marron

FINITION METAL

6. bruni
7. bronze cuivré

3

INSERTI BASE / BASE INSERTS / BASIS EINLAGE / INSERTS BASE

STANDARD:

nella stessa finitura della base / in the same finish as the base / im gleichen Ausführung wie die Basis / dans la même finition de la base

OPTIONAL LEGNO



1. noce canaletto
2. rovere spazzolato termotrattato
3. rovere spazzolato naturale
4. rovere spazzolato grigio antracite

CERAMICA LUCIDA



5. Calacatta
6. Onice oro
7. grigio Ardesia
8. grigio grafite
9. bianco iridium

METALLO VERNICIATO OPACO



10. bianco
11. grigio antracite
12. bordeaux
13. tortora
14. marrone

WOOD

1. walnut Canaletto
2. heat-treated polished oak
3. natural polished oak
4. anthracite grey polished oak

GLOSSY CERAMIC

5. Calacatta
6. Gold onice

MAT CERAMIC

7. Ardesia grey
8. graphite grey
9. iridium white

MAT PAINTED METAL

10. white
11. anthracite grey
12. bordeaux
13. dove grey
14. brown

HOLZ

1. Nussbaum Canaletto
2. Eiche thermo-behandelte poliert
3. Eiche Natur poliert
4. Eiche Anthrazitgrau poliert

GLÄNZED KERAMIK

5. Calacatta
6. Gold onice

MATT KERAMIK

7. Ardesia Grau
8. Graphitgrau
9. Iridium Weiss

METALL MATT LACKIERT

10. Weiss
11. Anthrazitgrau
12. Bordeaux
13. Taubengrau
14. Braun

BOIS

1. noyer Canaletto
2. rouvre brossé traité thermiquement
3. rouvre brossé naturel
4. rouvre brossé gris anthracite

CÉRAMIQUE BRILLANTE

5. Calacatta
6. Onice d'or

CÉRAMIQUE OPAQUE

7. gris Ardesia
8. gris graphite
9. blanc iridium

MÉTAL VERNI OPAQUE

10. blanc
11. gris anthracite
12. bordeaux
13. gris tourterelle
14. marron

DIMENSIONI / DIMENSIONS / GRÖSSEN / DIMENSIONS

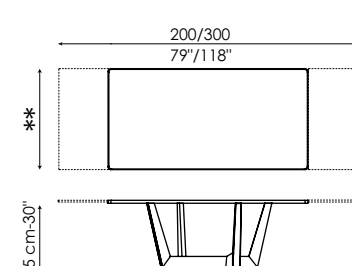
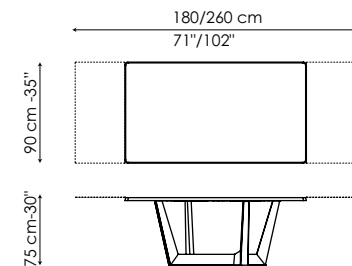
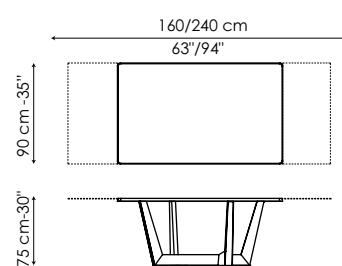

** 99 cm - 39"
laccato, impiallacciato, cristallo / lacquered, veneered wood, glass / Lackiert, Holz furniert, Glas / laqué, bois plaqué, cristal
100 cm - 39,4"
ceramica / ceramic / Keramik / céramique



1

FINITURA PIANO / TOP FINISH / PLATTE AUSFÜHRUNG / FINITION PLAN

CRISTALLO

- 1. acidato nero
- 2. extrachiaro acid. bianco

LEGNO MASSELLO

- 3. noce 400
- 4. noce americano

LEGNO MASSELLO CON NODI

- 5. rovere spazzolato naturale

LEGNO IMPIALLACCIATO

- 6. noce canaletto
- 7. rovere naturale
- 8. rovere grigio antracite
- 9. rovere termotrattato

CERAMICA LUCIDA

- 10. Calacatta
- 11. Onice oro

CERAMICA OPACA

- 12. grigio grafite
- 13. bianco iridium
- 14. grigio Ardesia

GLASS

- 1. acid-treated black
- 2. extra-light acid-treated white

SOLID WOOD

- 3. walnut 400
- 4. American walnut

SOLID WOOD WITH KNOTS

- 5. natural polished oak

VENEREED WOOD

- 6. Canaletto walnut
- 7. natural oak
- 8. anthracite grey oak
- 9. heat-treated oak

GLOSSY CERAMIC

- 10. Calacatta
- 11. Gold onice

MAT CERAMIC

- 12. graphite grey
- 13. iridium white
- 14. Ardesia grey

GLAS

- 1. Geätztes Schwarz
- 2. Geätztes extra-hell Weiss

MASSIVHOLZ

- 3. Nussbaum 400
- 4. Amerikaner Nussbaum

MASSIVHOLZ MIT KNOTEN

- 5. Eiche Natur poliert

HOLZ FURNIERT

- 6. Nussbaum Canaletto
- 7. Eiche Natur
- 8. Eiche Anthrazitgrau
- 9. thermo-behandelte Eiche

GLÄNZED KERAMIK

- 10. Calacatta
- 11. Gold onice

MATT KERAMIK

- 12. Graphitgrau
- 13. Iridium Weiss
- 14. Ardesia Grau

CRISTAL

- 1. cristal traité à l'acide noir
- 2. cristal extra-clair traité à l'acide blanc

BOIS MASSIF

- 3. noyer 400
- 4. noyer américain

BOIS MASSIF AVEC NOEUDS

- 5. rouvre brossé naturel

BOIS PLAQUÉ

- 6. noyer Canaletto
- 7. rouvre naturel
- 8. rouvre gris anthracite
- 9. rouvre traité thermiquement

CÉRAMIQUE BRILLANTE

- 10. Calacatta
- 11. Onice d'or

CÉRAMIQUE OPAQUE

- 12. gris graphite
- 13. blanc iridium
- 14. gris Ardesia

2

FINITURA BASE / BASE FINISH / BASIS AUSFÜHRUNG / FINITION BASE

METALLO VERNICIATO

- 1. bianco lucido
- 2. bianco opaco
- 3. grigio antracite opaco

METALLO FINITURA

- 4. acciaio spazzolato
- 5. acciaio spazzolato finitura nickel
- 6. decapato
- 7. bronzo rame

PAINTED METAL

- 1. glossy white
- 2. mat white
- 3. mat anthracite grey

METAL FINISH

- 4. polished steel
- 5. nickel finish polished steel
- 6. pickled
- 7. copper bronze

METALL LACKIERT

- 1. Weiss glänzend
- 2. Weiss matt
- 3. Anthrazitgrau matt

METALL AUSFÜHRUNG

- 4. Stahl poliert
- 5. Stahl poliert Nickel Ausführung
- 6. Stahlgrau
- 7. Kupferbronze

MÉTAL VERNI

- 1. blanc brillant
- 2. blanc opaque
- 3. gris anthracite opaque

MÉTAL FINITION

- 4. acier brossé
- 5. acier brossé finition nickel
- 6. décapé
- 7. bronze cuivre

DIMENSIONI / DIMENSIONS / GRÖSSEN / DIMENSIONS

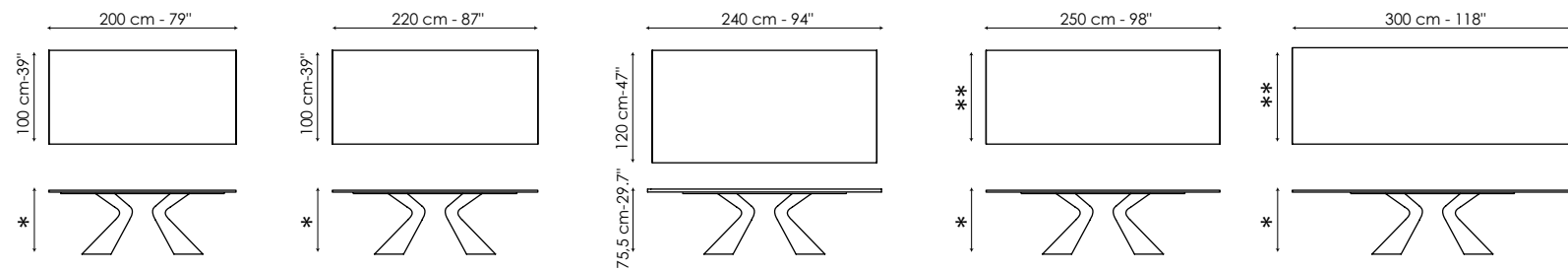

* 76 cm - 29.9" legno / wood / Holz / bois
 75,5 cm - 29.7" cristallo, ceramica / glass, ceramic / glas, keramik / cristal, céramique

* 76 cm - 29.9" legno / wood / Holz / bois
 75,5 cm - 29.7" cristallo, ceramica / glass, ceramic / glas, keramik / cristal, céramique

disponibile solo in ceramica Calacatta, Onice oro, Grigio Ardesia / available only in ceramic Calacatta, Ardesia grey, Gold onice / Achtteckig Ausführung nur aus Keramik Calacatta, Ardesia Grau, Gold onice / disponible seulement en céramique Calacatta, gris Ardesia, Onice d'or

* 76 cm - 29.9" legno / wood / Holz / bois
 75,5 cm - 29.7" cristallo, ceramica / glass, ceramic / glas, keramik / cristal, céramique

** 100 cm - 39" legno, cristallo, ceramica / wood, glass, ceramic / Holz, glas, keramik / bois, cristal, céramique
 110 cm - 43" legno con bordi naturali / wood with natural edges / massive Tiescherplatte mit Echtholzurnier / bois avec contour naturel

* 76 cm - 29.9" legno / wood / Holz / bois
 75,5 cm - 29.7" cristallo, ceramica / glass, ceramic / glas, keramik / cristal, céramique

** 100 cm - 39" ceramica bianco iridium, grigio grafite
 108 cm - 42,5" legno, cristallo, ceramica Calacatta, grigio Ardesia, Onice oro / wood, glass, ceramic Calacatta, Ardesia grey, Gold onice / Holz, glas, Keramik Calacatta, Ardesia Grau, Gold onice / bois, cristal, céramique Calacatta, gris Ardesia, Onice d'or
 120 cm - 47" legno con bordi naturali, ceramica Calacatta, grigio Ardesia, Onice oro / wood with natural edges, ceramic Calacatta, Ardesia grey, Gold onice / massive Tiescherplatte mit Echtholzurnier, Keramik Calacatta, Ardesia Grau, Gold onice / bois avec contour naturel, céramique Calacatta, gris Ardesia, Onice d'or

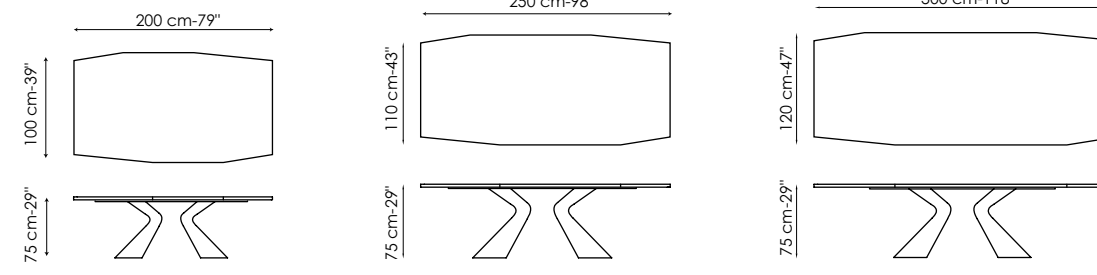

disponibile solo in ceramica Calacatta / available only in Calacatta ceramic / Achtteckig Ausführung nur aus Keramik Calacatta / disponible seulement en céramique Calacatta

disponibile solo in ceramica Calacatta / available only in Calacatta ceramic / Achtteckig Ausführung nur aus Keramik Calacatta / disponible seulement en céramique Calacatta

disponibile solo in ceramica Calacatta / available only in Calacatta ceramic / Achtteckig Ausführung nur aus Keramik Calacatta / disponible seulement en céramique Calacatta

pag. 34, 35, 36-37:
 250 cm - versione Octagonal, piano ceramica Calacatta, base grigio antracite / Octagonal version, Calacatta ceramic top, anthracite grey base / version Octagonal, plan en céramique Calacatta, base gris anthracite / Octagonal Version, Calacatta Keramik Platte, Anthrazitgrau Basis

pag. 38-39, 40, 41:
 250 cm - piano ceramica Onice oro, base bronzo-rame / gold Onice ceramic top, copper-bronze base / plan en céramique Onice d'or, base bronze-cuivre / Gold Onice Keramik Platte, Kupferbronze Basis



①

FINITURA PIANO / TOP FINISH / PLATTE AUSFÜHRUNG / FINITION PLAN

LACCATO	IMPIALLACCIATO LEGNO	LEGNO MASSELLO
1. bianco opaco	2. noce canaletto	3. noce americano
6. acidato nero	7. extrachiaro acidato bianco	4. rovere spazzolato naturale
CRISTALLO		5. rovere spazzolato grigio antracite
8. Calacatta	9. Onice oro	CERAMICA OPACA
11. Calacatta	12. Carrara	10. grigio Ardesia
MARMO LUCIDO O OPAO	13. Marquinia	
	14. Emperador	

LACQUERED	LACKIERT	LAQUÉ
1. mat white	1. Weiss matt	1. blanc opaque
VENEERED WOOD	HOLZ FURNIERT	BOIS PLAQUÉ
2. walnut Canaletto	2. Nussbaum Canaletto	2. noyer Canaletto
SOLID WOOD	MASSIVHOLZ	BOIS MASSIF
3. American walnut	3. Amerikaner Nussbaum	3. noyer américain
4. natural polished oak	4. Eiche Natur poliert	4. rouvre brossé naturel
5. anthracite grey polished oak	5. Eiche Anthrazitgrau poliert	5. rouvre brossé gris anthracite
GLASS	GLAS	CRISTAL
6. acid-treated black	6. geätztes Schwarz	6. traité à l'acide noir
7. extra-light acid treated white	7. geätztes extra-hell Weiss	7. extra-clair traité à l'acide blanc
GLOSSY CERAMIC	GLÄNZED KERAMIK	CÉRAMIQUE BRILLANTE
8. Calacatta	8. Calacatta	8. Calacatta
9. Gold onice	9. Gold Onice	9. Onice d'or
MAT CERAMIC	MATT KERAMIK	CÉRAMIQUE OPAQUE
10. Ardesia grey	10. Ardesia Grau	10. gris Ardesia
GLOSSY OR MAT MARBLE	GLÄNZEND ODER MATT MARMOR	MARBRE BRILLANT OU OPAQUE
11. Calacatta	11. Calacatta	11. Calacatta
12. Carrara	12. Carrara	12. Carrara
13. Marquinia	13. Marquinia	13. Marquinia
14. Emperador	14. Emperador	14. Emperador

②

FINITURA BASE / BASE FINISH / BASIS AUSFÜHRUNG / FINITION BASE

METALLO VERNICIATO OPAO	MAT PAINTED METAL	METALL MATT LACKIERT	MÉTAL VERNI OPAQUE
1. bianco	1. anthracite grey	1. Anthrazitgrau	1. gris anthracite
2. grigio antracite	2. white	2. Weiss	2. blanc
3. bordeaux	3. bordeaux	3. Bordeaux	3. bordeaux
4. tortora	4. dove grey	4. Taubengrau	4. gris tourterelle
5. marrone	5. brown	5. Braun	5. marron
METALLO FINITURA	METAL FINISH	METALL AUSFÜHRUNG	FINITION MÉTAL
6. rame opaco	6. mat copper	6. Kupfer matt	6. cuivre opaque
7. oltone opaco	7. mat brass	7. Messing matt	7. laiton opaque

DIMENSIONI / DIMENSIONS / GRÖSSEN / DIMENSIONS

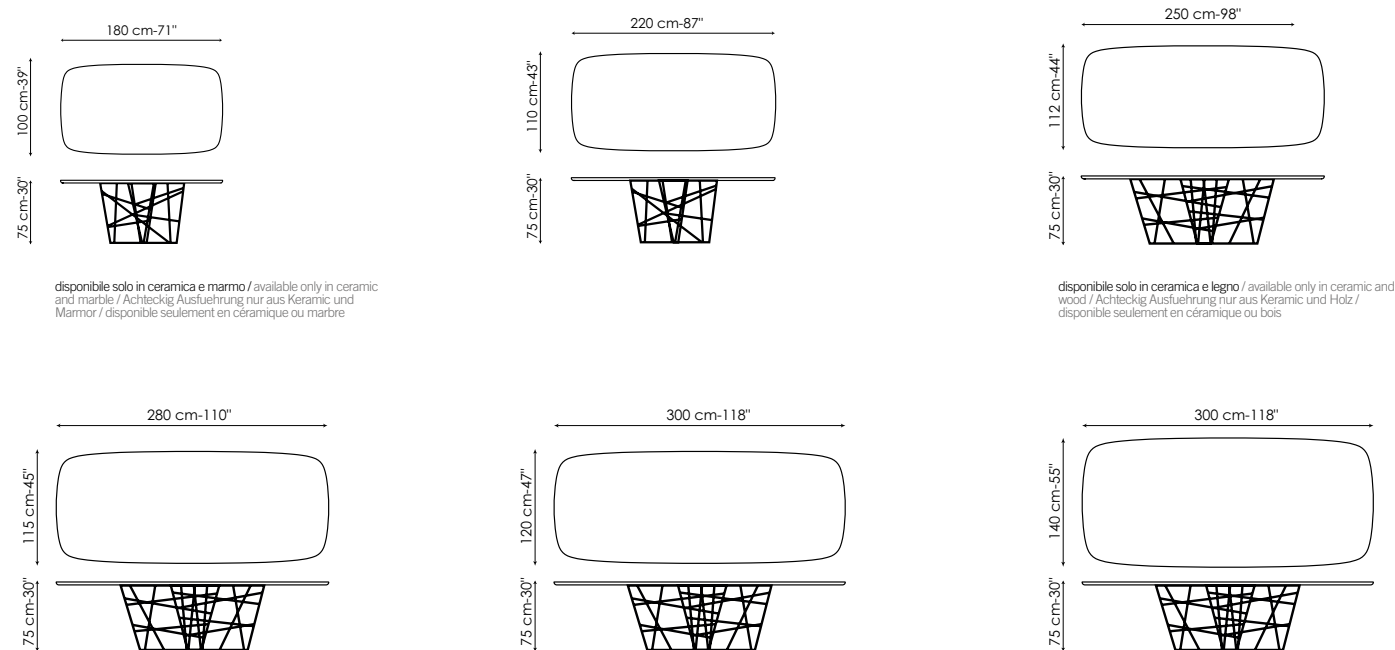

disponibile solo in ceramica e marmo / available only in ceramic and marble / Achteckig Ausführung nur aus Keramik und Marmor / disponible seulement en céramique ou marbre

disponibile solo in ceramica e legno / available only in ceramic and wood / Achteckig Ausführung nur aus Keramik und Holz / disponible seulement en céramique ou bois

disponibile solo in ceramica / available only in ceramic / Achteckig Ausführung nur aus Keramik / disponible seulement en céramique

pag. 24-25, 26, 27, 28-29:
280 cm – piano ceramica grigio ardesia, base grigio antracite / ardesia grey ceramic top, anthracite grey base / plan en céramique gris ardesia, base gris anthracite / Ardesia Grau Keramik Platte, Anthrazitgrau Basis

pag. 30-31:
300x140 cm – piano ceramica grigio ardesia, base rame opaco / ardesia grey ceramic top, mat copper base / plan en céramique gris ardesia, base cuivre opaque / Ardesia Grau Keramik Platte, Kupfer matt Basis

pag. 32:
220 cm – piano rovere spazzolato grigio antracite, base grigio antracite / anthracite grey polished oak top, anthracite grey base / plan en rouvre brossé gris anthracite, base gris anthracite / Eiche Anthrazitgrau polierte Platte, Anthrazitgrau Basis





pag. 33:
280 cm – piano noce americano, base grigio antracite / American walnut top, anthracite grey base / plan en noyer américain, base gris anthracite / Amerikaner Nussbaum Platte, Anthrazitgrau Basis



①

FINITURA PIANO E PROLUNGHE / TOP AND LEAVES FINISH / PLATTE UND VERLÄNGERUNGEN AUSFÜHRUNG / FINITION PLAN ET RALLONGES

CRISTALLO

- | | | | |
|--|---|---|---|
| <p>1.  extrachiaro verniciato/bianco/laccato bianco opaco</p> | <p>2.  acidato nero/laccato nero opaco</p> | <p>3.  extrachiaro acidato bianco/laccato bianco opaco</p> | <p>4.  acidato grigio antracite/laccato grigio antracite opaco</p> |
|--|---|---|---|

CERAMICA LUCIDA

5.  Calacatta/laccato bianco opaco*

CERAMICA OPACA

6.  grigio Ardesia/laccato grigio antracite opaco*

* prolunga disponibile anche in ceramica

GLASS

1. extra-light painted white/lacquered mat white
2. acid treated black/lacquered mat black
3. extra-light acid treated white/lacquered mat white
4. acid treated anthracite grey/lacquered mat anthracite grey

GLAS

1. extra-hell Weiss lackiert/Lackiert Weiss mat
2. Geätztes Schwarz/Lackiert Weiss mat
3. Geätztes extra-hell Weiss/Lackiert Weiss mat
4. Geätztes Anthrazitgrau/Lackiert Anthrazitgrau mat

CRISTAL

1. extra-clair verni blanc/laqué blanc opaque
2. traité à l'acide noir/laqué noir opaque
3. extra-clair traité à l'acide blanc/laqué blanc opaque
4. traité à l'acide gris anthracite/laqué gris anthracite opaque

GLOSSY CERAMIC

5. Calacatta/lacquered mat white*

GLÄNZEND KERAMIK

5. Calacatta/Lackiert Weiss mat*

CÉRAMIQUE BRILLANTE

5. Calacatta/laqué blanc opaque*

MAT CERAMIC

6. Ardesia grey/lacquered mat anthracite grey*

MATT KERAMIK

6. Ardesia Grau/Lackiert Anthrazitgrau mat*

CÉRAMIQUE OPAQUE

6. gris Ardesia/laqué gris anthracite opaque*

* leaf also available in ceramic

* Verlängerung verfügbar auch auf Keramik

* rallonge disponible aussi en céramique

DIMENSIONI / DIMENSIONS / GRÖSSEN / DIMENSIONS

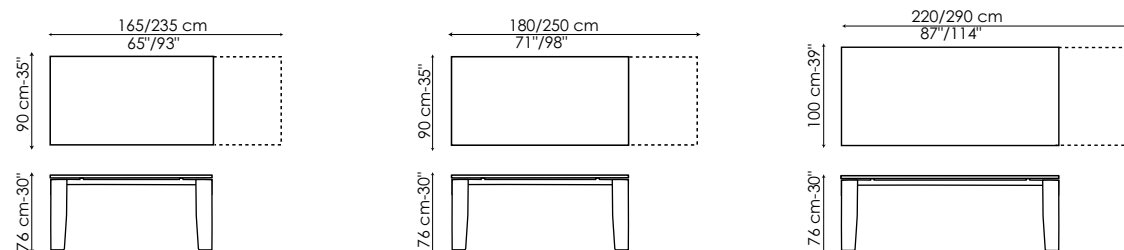

②

FINITURA GAMBE / LEGS FINISH / BEINE AUSFÜHRUNG / FINITION PIEDS

LEGNO MASSELLO

- | | | |
|--|--|--|
| <p>1.  noce americano</p> | <p>2.  rovere spazzolato naturale</p> | <p>3.  rovere spazzolato grigio antracite</p> |
|--|--|--|

SOLID WOOD

1. American walnut
2. natural polished oak
3. anthracite grey polished oak

MASSIVHOLZ

1. Amerikaner Nussbaum
2. Eiche Natur poliert
3. Eiche Anthrazitgrau poliert



BOIS MASSIF

1. noyer américain
2. rouvre brossé naturel
3. rouvre brossé gris anthracite

③

FINITURA STRUTTURA / FRAME FINISH / STRUKTUR AUSFÜHRUNG / FINITION STRUCTURE

METALLO VERNICIATO OPACO

- | | | |
|--|--|--|
| <p>1.  bianco</p> | <p>2.  grigio antracite</p> | <p>3.  nero</p> |
|--|--|--|

MAT PAINTED METAL

1. white
2. anthracite grey
3. black

METALL LACKIERT MATT

1. Weiss
2. Anthrazitgrau
3. Schwarz

MÉTAL VERNI OPAQUE

1. blanc
2. gris anthracite
3. noir

pag. 42-43, 44, 45:

220-280 cm – piano e prolunga ceramica grigio ardesia, struttura grigio antracite, gambe noce americano / ardesia grey ceramic top and leaf, anthracite grey frame, American walnut legs / plan et rallonge en céramique gris ardesia, structure gris anthracite, pieds en noyer américain / Ardesia Grau Keramik Platte und Verlängerungen, Anthrazitgrau Struktur, Amerikaner Nussbaum Beine

BARDOT

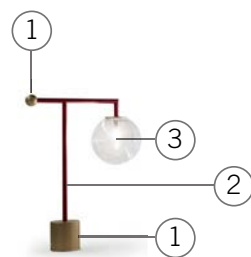

1
FINITURA BASE E SFERA / BASE AND METAL SPHERE FINISH / BASIS UND METALLKUGEL AUSFÜHRUNG / FINITION BASE ET SPHÈRE EN MÉTAL

METALLO FINITURA	METAL FINISH	METALL AUSFÜHRUNG	FINITION MÉTAL
1. ottone opaco	1. mat brass	1. Messing matt	1. laiton opaque

2
FINITURA STRUTTURA / FRAME FINISH / GESTELL AUSFÜHRUNG / FINITION STRUCTURE

METALLO VERNICIATO OPACO	MAT PAINTED METAL	METALL LACKIERT MATT	MÉTAL VERNI OPAQUE
1. bianco	1. white	1. Weiss	1. blanc
2. grigio antracite	2. anthracite grey	2. Anthrazitgrau	2. gris anthracite
3. racing green	3. racing green	3. Racing Green	3. racing green
4. bordeaux	4. bordeaux	4. Bordeaux	4. bordeaux
5. azzurro artico	5. arctic blue	5. Arktisch Blau	5. bleu arctique
6. mattone	6. brick red	6. Ziegelrot	6. brique

3
ILLUMINAZIONE / LIGHTING / BELEUCHTUNG / LUMIÈRE

LED	LED	LED	LED

DIMENSIONI / DIMENSIONS / GRÖßEN / DIMENSIONS

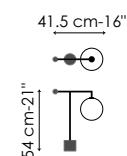

pag. 97:
 rosso mattone / brick red / brique / Ziegelrotgrau

pag. 98-99:
 bordeaux, bianco, racing green, rosso mattone, azzurro artico, grigio antracite / bordeaux, white, racing green, brick red, arctic blue, anthracite grey / bordeaux, blanc, racing green, brique, bleu arctique, gris anthracite / Bordeaux, Weiss, Racing Green, Ziegelrot, Arktisch Blau, Anthrazitgrau

CABINET DE CURIOSITÉ

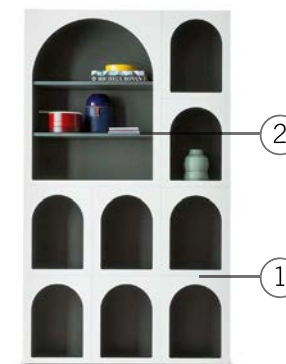

1
FINITURA STRUTTURA / FRAME FINISH / GESTELL AUSFÜHRUNG / FINITION STRUCTURE

LEGNO LACCATO OPACO	MAT LACQUERED WOOD	HOLZ LACKIERT MATT	BOIS LAQUÉ OPAQUE
1. FRONTE: bianco	1. FRONT: white	1. VORDERSCITE: Weiss	1. DEVANT: blanc
2. FIANCO ED INTERNO: grigio antracite	2. SIDE AND INSIDE: anthracite grey	2. SEITE UND INNEN: Anthrazitgrau	2. CÔTÉ ET INTÉRIEUR: gris anthracite

2
FINITURA RIPIANI / SHELVES FINISH / REGALE AUSFÜHRUNG / FINITION PLANS

LEGNO LACCATO OPACO	MAT LACQUERED WOOD	HOLZ LACKIERT MATT	BOIS LAQUÉ OPAQUE
1. grigio antracite	1. anthracite grey	1. Holz Anthrazitgrau	1. gris anthracite

DIMENSIONI / DIMENSIONS / GRÖßEN / DIMENSIONS

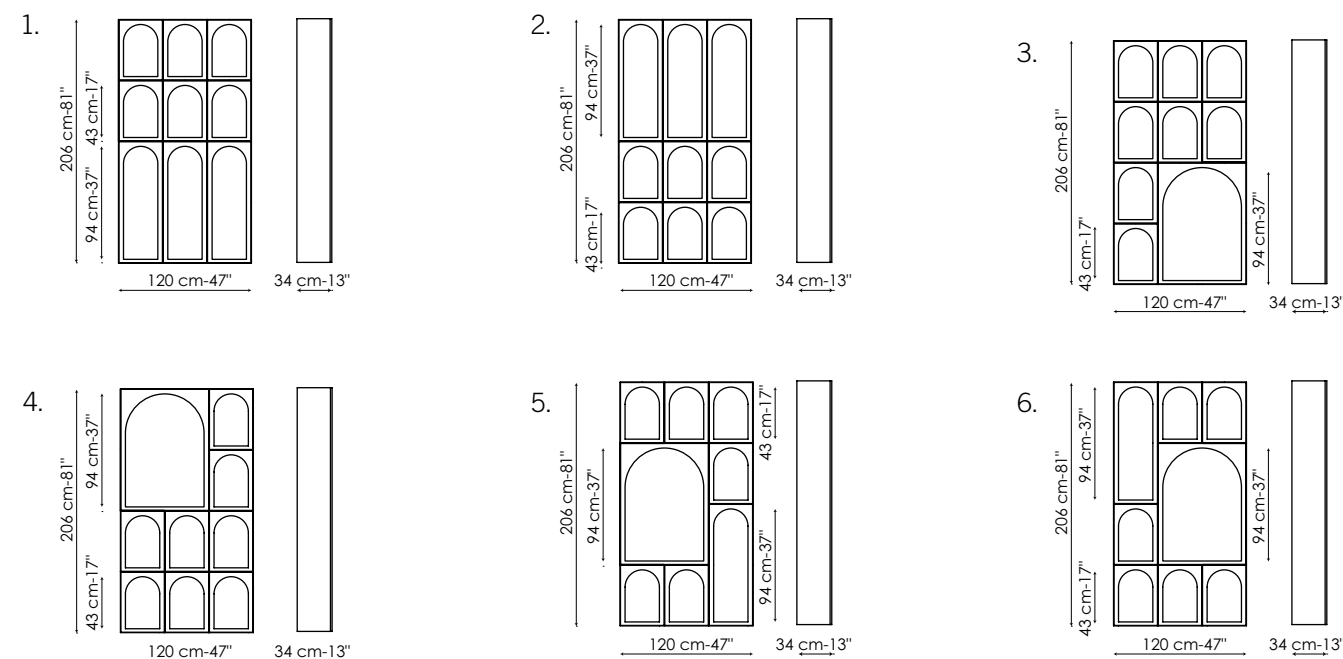

pag. 78-79:
 combinazione con moduli / combination with modules / combinaison avec modules / Kombination mit Modulen n°4 + n°1 + n°6

pag. 80:
 combinazione con moduli / combination with modules / combinaison avec modules / Kombination mit Modulen n°4 + n°1 + n°6 + 2 ripiani / shelves / tablets / Regale 80 cm + 2 ripiani / shelves / tablets / Regale 40 cm

pag. 81:
 modulo / module / module / Modul n°4 + 2 ripiani / shelves / tablets / Regale 80 cm

pag. 82-83:
 modulo / module / module / Modul n°5 + 1 ripiano / shelf / tablet / Regal 80 cm + 2 ripiani / shelves / tablets / Regale 40 cm

DAY

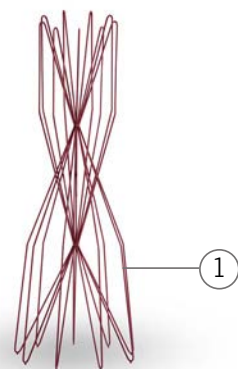

①

FINITURA STRUTTURA / FRAME FINISH / GESTELL AUSFÜHRUNG / FINITION STRUCTURE

METALLO VERNICIATO OPACO



MAT PAINTED METAL

1. white
2. black
3. anthracite grey
4. red
5. dove grey
6. brown
7. green
8. blue
9. saffron yellow
10. mint green
11. orange
12. racing green
13. coffee brown
14. bordeaux
15. arctic blue
16. brick red

METALL MAT LACKIERT

1. Weiss
2. Schwarz
3. Anthrazitgrau
4. Rot
5. Taubengrau
6. Braun
7. Grün
8. Blau
9. Safrangelb
10. Minzgrün
11. Orange
12. Racing Green
13. Coffee Brown
14. Bordeaux
15. Arktisch Blau
16. Ziegelrot

MÉTAL VERNI OPAQUE

1. blanc
2. noir
3. gris anthracite
4. rouge
5. gris tourterelle
6. marron
7. vert
8. bleu
9. jaune safran
10. vert menthe
11. orange
12. racing green
13. coffee brown
14. bordeaux
15. bleu artique
16. brique

DIMENSIONI / DIMENSIONS / GRÖßEN / DIMENSIONS

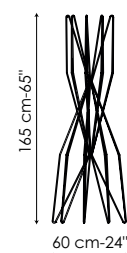

pag. 88, 89:
bordeaux / bordeaux / bordeaux / Bordeaux

FRAGMENT



①

FINITURA PIANO / TOP FINISH / PLATTE AUSFÜHRUNG / FINITION PLAN

IMPIALLACCIATO LEGNO



TERRAZZO

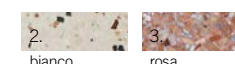

MARMO



VENEERED WOOD

1. heat-treated oak

TERRAZZO

2. white
3. pink

MARBLE

4. Calacatta
5. Carrara
6. Marquinia
7. Emperador

HOLZ FURNIERT

1. Eiche thermo-behandelte

TERRAZZO

2. Weiss
3. Rosa

MARMOR

4. Calacatta
5. Carrara
6. Marquinia
7. Emperador

BOIS PLAQUÉ

1. rouvre traité thermiquement

TERRAZZO

2. blanc
3. rose

MARBRE

4. Calacatta
5. Carrara
6. Marquinia
7. Emperador

②

FINITURA GAMBE / LEGS FINISH / BEINE AUSFÜHRUNG / FINITION PIEDS

METALLO VERNICIATO OPACO

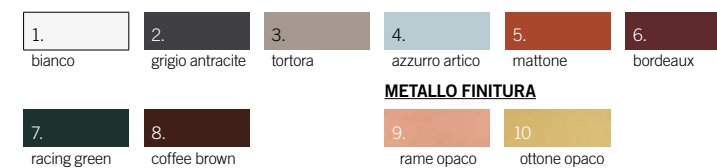

METALLO FINITURA

MAT PAINTED METAL

1. white
2. anthracite grey
3. dove grey
4. arctic blue
5. brick red
6. bordeaux
7. racing green
8. coffee brown

METALL MAT LACKIERT

1. Weiss
2. Anthrazitgrau
3. Taubengrau
4. Arktisch Blau
5. Ziegelrot
6. Bordeaux
7. Racing Green
8. Coffee Brown

MÉTAL VERNI OPAQUE

1. blanc
2. gris anthracite
3. gris tourterelle
4. bleu artique
5. brique
6. bordeaux
7. racing green
8. coffee brown

METAL FINISH

9. mat copper
10. mat brass

METALL AUSFÜHRUNG

9. Kupfer matt
10. Messing matt

FINITION MÉTAL

9. cuivre opaque
10. laiton opaque

DIMENSIONI / DIMENSIONS / GRÖßEN / DIMENSIONS

SMALL

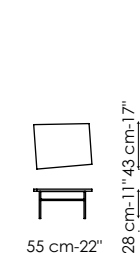

MEDIUM

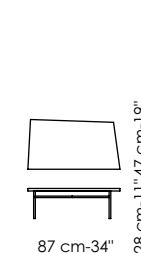

LARGE

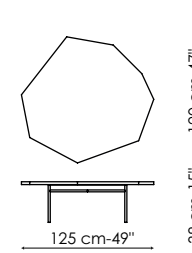

pag. 94, 95:

SMALL – piano Terrazzo rosa, gambe grigio antracite / pink Terrazzo top, anthracite grey legs / plan en Terrazzo rose, pieds gris anthracite / Pink Terrazzo Platte, Anthrazitgrau Beine

MEDIUM – piano rovere termotrattato, gambe grigio antracite / heat-treated oak top, anthracite grey legs / plan en rouvre traité thermiquement, pieds gris anthracite / thermo-behandelte Eiche Platte, Anthrazitgrau Beine

LARGE – piano Terrazzo bianco, gambe grigio antracite / white Terrazzo top, anthracite grey legs / plan en Terrazzo blanc, pieds gris anthracite / Weiss Terrazzo Platte, Anthrazitgrau Beine

MOVIE



①

RIVESTIMENTO / UPHOLSTERY / BEZUG / REVÊTEMENT

tessuto elastico
tessuto

stretch fabric
fabric

Elastischer Stoff
Stoff

tissu élastique
tissu

②

FINITURA BASE / BASE FINISH / BASIS AUSFÜHRUNG / FINITION BASEME

METALLO VERNICIATO OPACO



METALLO FINITURA

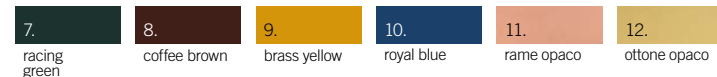

METAL MAT PAINTED

- white
- anthracite grey
- black
- arctic blue
- brick red
- bordeaux
- racing green
- coffee brown
- brass yellow
- royal blue

METAL FINISH

- mat copper
- mat brass

METALL MAT LACKIERT

- Weiss
- Anthrazitgrau
- Schwarz
- Arktisch Blau
- Ziegelrot
- Bordeaux
- Racing Green
- Coffee Brown
- Brass yellow
- Royal Blue

METALL AUSFÜHRUNG

- Kupfer matt
- Messing matt

MÉTAL VERNI OPAQUE

- blanc
- gris anthracite
- noir
- bleu artique
- brique
- bordeaux
- racing green
- coffee brown
- brass yellow
- royal blue

FINITION MÉTAL

- cuivre opaque
- laiton opaque

DIMENSIONI / DIMENSIONS / GRÖßEN / DIMENSIONS

MEDIUM

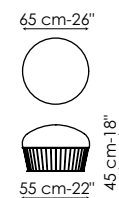

LARGE

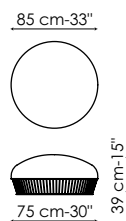

pag. 90, 91:

LARGE – tessuto SA35, struttura grigio antracite / fabric SA35, anthracite grey frame / tissu SA35, structure gris anthracite / Stoff SA35, Anthrazitgrau Struktur

MEDIUM – tessuto SA18, struttura grigio antracite / fabric SA18, anthracite grey frame / tissu SA18, structure gris anthracite / Stoff SA18, Anthrazitgrau Struktur

NOTE SIDEBORD



①

FINITURA STRUTTURA (A) E ASSI (B) / FRAME (A) AND BEAMS (B) FINISH / GESTELLE (A) UND STÜTZEN (B) AUSFÜHRUNG / FINITION STRUCTURE (A) ET AXES (B)



COMBINAZIONE 1
struttura: laccato opaco bianco (A)
assi: laccato opaco bianco (B)



COMBINAZIONE 2
struttura: noce canaletto (A)
assi: laccato opaco marrone (B)

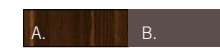

COMBINAZIONE 3
struttura: rovere termotrattato (A)
assi: laccato opaco marrone (B)

COMBINAZIONE 1
frame: mat lacquered white (A)
beams: mat lacquered white (B)

KOMBINATION 1
Struktur: Weiss Lackiert matt (A)
Stützen: Weiss Lackiert matt (B)

COMBINAISON 1
structure: laqué blanc opaque (A)
axes: laqué blanc opaque (B)

COMBINAZIONE 2
frame: canaletto walnut (A)
beams: mat lacquered brown (B)

KOMBINATION 2
Struktur: Nussbaum Canaletto (A)
Stützen: Braun Lackiert matt (B)

COMBINAISON 2
structure: noyer canaletto (A)
axes: laqué marron opaque (B)

COMBINAZIONE 3
frame: heat-treated oak (A)
beams: mat lacquered brown (B)

KOMBINATION 3
Struktur: thermo-behandeltes Eiche (A)
Stützen: Braun Lackiert matt (B)

COMBINAISON 3
structure: rouvre traité thermique (A)
axes: laqué marron opaque (B)

DIMENSIONI / DIMENSIONS / GRÖßEN / DIMENSIONS

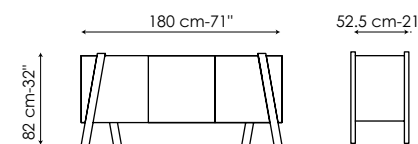

3 ante / 3 doors / 3 Türen / 3 portes

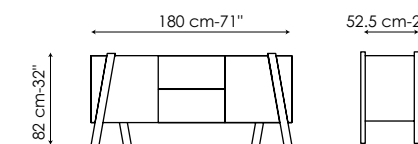

2 ante, cassetto, ribalta / 2 doors, drawer, flap door / 2 Türen, Lade, Klapptüre / 2 portes, tiroir, porte basculante

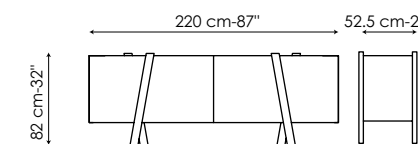

4 ante / 4 doors / 4 Türen / 4 portes

pag. 92, 93:

240 cm – struttura in noce Canaletto, assi laccati marrone opaco / Canaletto walnut frame, mat lacquered beams / structure en noyer Canaletto, axes laqués marron opaque / Nussbaum Canaletto Struktur, matt Braun lackierte Stützen

OUTLINE



①

FINITURA STRUTTURA / FRAME FINISH / GESTELL AUSFÜHRUNG / FINITION STRUCTURE

IMPIALLACCIATO LEGNO



1. noce canaletto

VENEERED WOOD

1. walnut Canaletto

HOLZ FURNIERT

2. Nussbaum Canaletto

BOIS PLAQUÉ

3. noyer Canaletto

②

FINITURA BASE / BASE FINISH / BASIS AUSFÜHRUNG / FINITION BASE

METALLO VERNICIATO OPACO

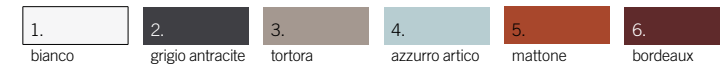

1. bianco 2. grigio antracite 3. tortora 4. azzurro artico 5. mattone 6. bordeaux



7. racing green 8. coffee brown

METALLO FINITURA

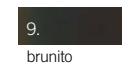

9. brunito

MAT PAINTED METAL

1. white
2. anthracite grey
3. dove grey
4. arctic blue
5. brick red
6. bordeaux
7. racing green
8. coffee brown

METAL FINISH

9. burnished

METALL MAT LACKIERT

1. Weiss
2. Anthrazitgrau
3. Taubengrau
4. Arktisch Blau
5. Ziegelrot
6. Bordeaux
7. Racing Green
8. Coffee Brown

METALL AUSFÜHRUNG

9. Brüniert

MÉTAL VERNI OPAQUE

1. blanc
2. gris anthracite
3. gris tourterelle
4. bleu artique
5. brique
6. bordeaux
7. racing green
8. coffee brown

FINITION MÉTAL

9. bruni

③

TOP IN CERAMICA / CERAMIC TOP / KERAMIC PLATTE / PLAN EN CÉRAMIQUE (optional)

CERAMICA LUCIDA

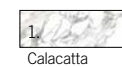

1. Calacatta

CERAMICA OPACA



2. Onice oro 3. grigio Ardesia

GLOSSY CERAMIC

1. Calacatta
2. Gold onice

MATT CERAMIC

3. Ardesia grey

GLÄNZED KERAMIK

1. Calacatta
2. Gold Onice

MATT KERAMIK

3. Ardesia Grau

CÉRAMIQUE BRILLANT

1. Calacatta
2. Onice d'or

CÉRAMIQUE OPAQUE

3. gris Ardesia

DIMENSIONI / DIMENSIONS / GRÖßEN / DIMENSIONS

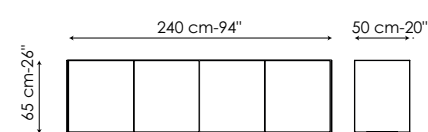
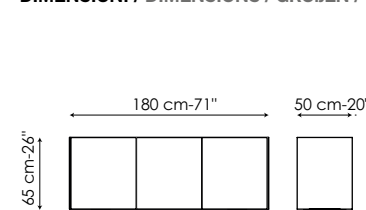

Base in metallo / metal base /
metall basis / base en metal

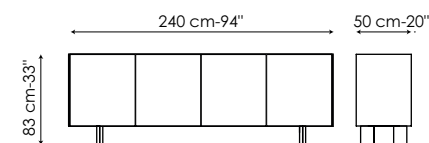
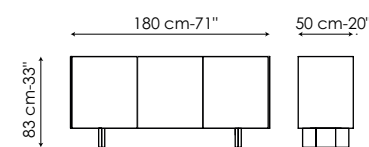

pag. 84, 85, 86:

240 cm – noce Canaletto, piano ceramica grigio ardesia, base in metallo grigio antracite / Canaletto walnut, ardesia grey ceramic, anthracite grey metal base / noyer Canaletto, plan en céramique gris ardesia, base en métal gris anthracite / Nussbaum Canaletto, Ardesia Grau Keramik Platte, Anthrazitgrau Metall Basis

pag. 86:

240 cm – noce Canaletto, piano ceramica Onice oro, base in metallo grigio antracite / Canaletto walnut, gold Onice ceramic, anthracite grey metal base / noyer Canaletto, plan en céramique Onice d'or, base en métal gris anthracite / Nussbaum Canaletto, Gold Onice Keramik Platte, Anthrazitgrau Metall Basis

pag. 86, 87:

240 cm – noce Canaletto, base in metallo grigio antracite / Canaletto walnut, anthracite grey metal base / noyer Canaletto, base en métal gris anthracite / Nussbaum Canaletto, Anthrazitgrau Metall Basis

LOCK, LOCK EGO, LOCK SOFT



1 RIVESTIMENTO / COVER / BEZUG / REVÊTEMENT

pelle / leather / Leder / cuir souple
 tessuto / fabric / Stoff / tissu

2 PIEDI-BASE / FEET-BASE / FÛÛBE-BASIS / PIEDS-BASE

VERNICIATO OPACO

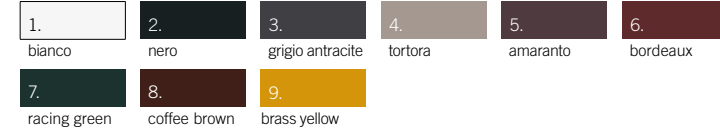

METALLO FINITURA

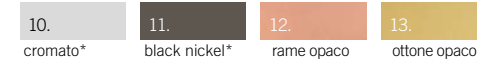

MAT PAINTED METAL

- white
- black
- anthracite grey
- dove grey
- amaranth
- bordeaux
- racing green
- coffee brown
- brass yellow

METAL FINISH

- chromed*
- black nickel*
- mat copper
- mat brass

* Not available for swivel Lock

METALL MAT LACKIERT

- Weiss
- Schwarz
- Anthrazitgrau
- Taubengrau
- Amaranth
- Bordeaux
- Racing Green
- Coffee Brown
- Brass yellow

METALL AUSFÛHRUNG

- Verchromt*
- Schwarz vernickelt*
- Kupfer matt
- Messing matt

* Nicht verfügbar für drehbaren Lock

MÉTAL VERNI OPAQUE

- blanc
- noir
- gris anthracite
- gris tourterelle
- amarante
- bordeaux
- racing green
- coffee brown
- brass yellow

FINITION MÉTAL

- chromé*
- noir nickel*
- cuivre opaque
- laiton opaque

* Pas disponible pour Lock pivotante

DIMENSIONI / DIMENSIONS / GRÖÛEN / DIMENSIONS

LOCK

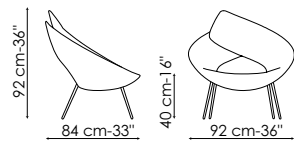

LOCK EGO

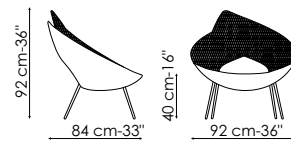

LOCK SOFT

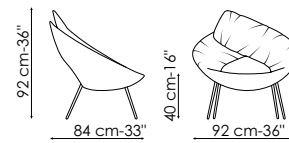

LOCK GIREVOLE / SWIVEL BASE / DREHBAREN / PIVOTANTE

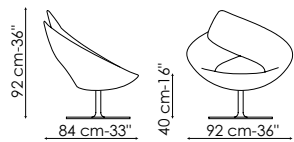

LOCK EGO GIREVOLE / SWIVEL BASE / DREHBAREN / PIVOTANTE

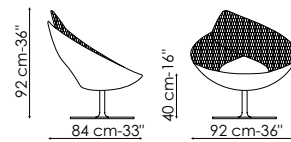

LOCK SOFT GIREVOLE / SWIVEL BASE / DREHBAREN / PIVOTANTE

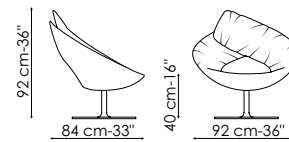

pag. 110, 113: EGO – tessuto 9B18, piedi grigio antracite / fabric 9B18, anthracite grey feet / tissu 9B18, pieds gris anthracite / Stoff 9B18, Anthrazitgrau FüÙe

pag. 111, 113: SOFT – pelle Capri L09, piedi neri / Capri leather L09, black feet / cuir souple Capri L09, pieds noirs / Leder Capri L09, Schwarze FüÙe

pag. 111, 113: tessuto MB85, piedi grigio antracite / fabric MB85, anthracite grey feet / tissu MB85, pieds gris anthracite / Stoff MB85, Anthrazitgrau FüÙe

pag. 112, 113: tessuto M75, base girevole brass yellow / fabric M75, brass yellow swivel base / tissu M75, base pivotante brass yellow / Stoff M75, Brass Yellow drehbare Basis

LOVY ARMCHAIR LOW, LOVY ARMCHAIR BERGÈRE



1 RIVESTIMENTO / COVER / BEZUG / REVÊTEMENT

tessuto / fabric / Stoff / tissu

2 PIEDI / FEET / FÛÛBE / PIEDS

VERNICIATO OPACO



METALLO FINITURA



MAT PAINTED METAL

- white
- black
- anthracite grey
- dove grey
- brown
- amaranth
- red

METAL FINISH

- chromed
- black nickel

METALL MAT LACKIERT

- Weiss
- Schwarz
- Anthrazitgrau
- Taubengrau
- Braun
- Amaranth
- Rot

METALL AUSFÛHRUNG

- Verchromt
- Schwarz vernickelt

MÉTAL VERNI OPAQUE

- blanc
- noir
- gris anthracite
- gris tourterelle
- marron
- amarante
- rouge

FINITION MÉTAL

- chromé
- noir nickel

DIMENSIONI / DIMENSIONS / GRÖÛEN / DIMENSIONS

LOW

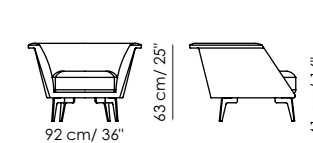

BERGÈRE

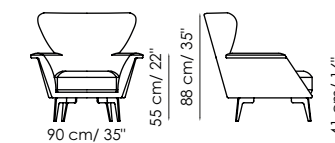

POUF 3 PIEDI / 3 FEET / 3 FÛÛSE / 3 PIEDS

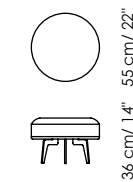

pag. 102, 103: LOW – tessuto MC10, piedi rossi / fabric MC10, red feet / tissu MC10, pieds rouges / Stoff MC10, Rote FüÙe pag. 104: BERGÈRE – tessuto MC19, piedi racing green / fabric MC19, racing green feet / tissu MC19, pieds racing green / Stoff MC19, Racing Green FüÙe

pag. 105: BERGÈRE + POUF 55 – tessuto MC19, piedi black nickel / fabric MC19, black nickel feet / tissu MC19, pieds black nickel / Stoff MC19, Schwarz vernickeliet FüÙe

PANORAMA ARMCHAIR



①

RIVESTIMENTO / COVER / BEZUG / REVÊTEMENT

pelle tessuto	leather fabric	Leder Stoff	cuir souple tissu
------------------	-------------------	----------------	----------------------

②

PIEDI / FEET / FÜßE / PIEDS

LEGNO COLOR

1.	grigio antracite
----	------------------

PAINTED WOOD

- anthracite grey

HOLZ

- Anthrazitgrau

BOIS TEINTÉ

- gris anthracite

DIMENSIONI / DIMENSIONS / GRÖßEN / DIMENSIONS

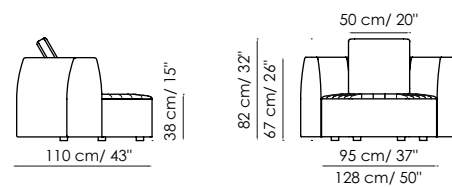

pag. 124-125:
POLTRONA – tessuto MC75, MC43 + pouf con ruote – tessuto MC75 / armchair – fabric MC75, MC43 + pouf on wheels – fabric MC75 / fauteuil – tissu MC75, MC43 + pouf avec rouettes – tissu MC75 / Sessel – Stoff MC75, MC43 + Pouf mit Räder – Stoff MC75

TIRELLA



①

RIVESTIMENTO / COVER / BEZUG / REVÊTEMENT

tessuto	fabric	Stoff	tissu
---------	--------	-------	-------

②

FINITURA BASE / BASE FINISH / BASIS AUSFÜHRUNG / FINITION BASE

METALLO VERNICIATO OPACO

1.	2.	3.	4.	5.	6.
bianco	grigio antracite	tortora	azzurro artico	amaranto	marrone

METALLO FINITURA

7.	8.	9.
nero	rame opaco	ottone opaco

MAT PAINTED METAL

- white
- anthracite grey
- dove grey
- arctic blue
- amaranth
- brown
- black

METAL FINISH

- mat copper
- mat brass

METALL MAT LACKIERT

- Weiss
- Anthrazitgrau
- Taubengrau
- Arktisch Blau
- Amaranth
- brown
- Schwarz

METALL AUSFÜHRUNG

- Kupfer matt
- Messing matt

MÉTAL VERNI OPAQUE

- blanc
- gris anthracite
- gris tourterelle
- bleu artique
- amarante
- marron
- blanc

FINITION MÉTAL

- cuivre opaque
- laiton opaque

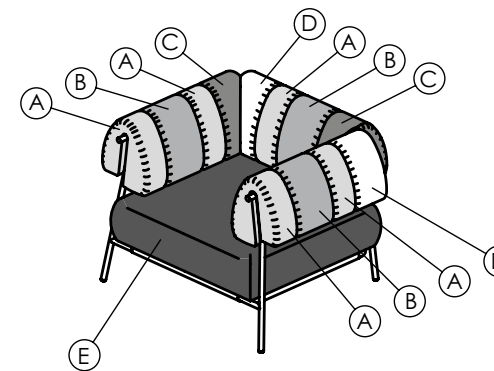

È possibile scegliere tessuti diversi per i moduli che compongono lo schienale e la seduta.
It is possible to choose different fabrics for the modules of the backrest and seating.
Verschiedene Stoffe für die Module, die den Rücken und den Sitz ausmachen, können ausgewählt werden.
On peut choisir des tissus différents pour les modules qui composent le dossier et l'assise.

DIMENSIONI / DIMENSIONS / GRÖßEN / DIMENSIONS

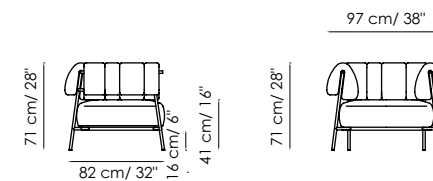

pag. 106, 107:
seduta tessuto SA26; schienale e braccioli tessuto SA25, SA17, SA26, SA23; struttura tortora / seat in fabric SA26; backrest and armrests in fabric SA25, SA17, SA26, SA23; dove grey frame / assise en tissu SA26; dossier et accoudoirs en tissu SA25, SA17, SA26, SA23; structure gris tourterelle / Sitz Stoff SA26; Rücken und Armlehnen Stoff SA25, SA17, SA26, SA23; Taubengrau Struktur

pag. 109:
seduta tessuto MA20; schienale e braccioli tessuto MC58; struttura marrone / seat in fabric MA20; backrest and armrests in fabric MC58; brown frame / assise en tissu MA20; dossier et accoudoirs en tissu MC58; structure marron / Sitz Stoff MA20; Rücken und Armlehnen Stoff MC58; Braun Struktur

pag. 108, 109:
seduta tessuto MA20; schienale e braccioli tessuto MC58, MA20; struttura marrone / seat in fabric MA20; backrest and armrests in fabric MC58, MA20; brown frame / assise en tissu MA20; dossier et accoudoirs en tissu MC58, MA20; structure marron / Sitz Stoff MA20; Rücken und Armlehnen Stoff MC58, MA20; Braun Struktur

ARNO SOFA



①

RIVESTIMENTO / COVER / BEZUG / REVÊTEMENT

pelle / tessuto leather / fabric Leder / Stoff cuir souple / tissu

②

PIEDI / FEET / FÜÙE / PIEDS

METALLO VERNICIATO OPACO

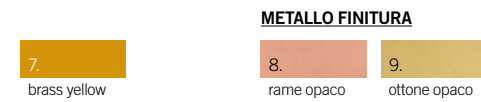
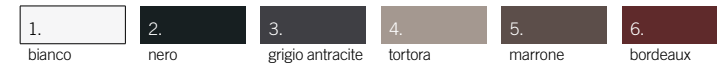

MAT PAINTED METAL

1. white
2. black
3. anthracite grey
4. dove grey
5. brown
6. bordeaux
7. brass yellow

METAL FINISH

8. mat copper
9. mat brass

METALL MAT LACKIERT

1. Weiss
2. Schwarz
3. Anthrazitgrau
4. Taubengrau
5. Braun
6. Bordeaux
7. Brass yellow

METALL AUSFÜHRUNG

8. Kupfer matt
9. Messing matt

MÉTAL VERNI OPAQUE

1. blanc
2. noir
3. gris anthracite
4. gris tourterelle
5. marron
6. bordeaux
7. brass yellow

FINITION MÉTAL

8. cuivre opaque
9. laiton opaque

DIMENSIONI / DIMENSIONS / GRÖÙEN / DIMENSIONS

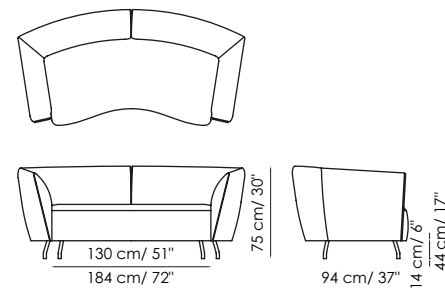

pag. 134, 135, 136-137:
tessuto MB72, piedi grigio antracite / fabric MB72, anthracite grey feet / tissu MB72, pieds gris anthracite /
Stoff MB72, Anthrazitgraue FüÙe

LOVY, LOVY EGO, LOVY LOW, LOVY HI



①

RIVESTIMENTO / COVER / BEZUG / REVÊTEMENT

tessuto fabric Stoff tissu

②

PIEDI / FEET / FÜÙE / PIEDS

METALLO VERNICIATO OPACO



MAT PAINTED METAL

1. white
2. black
3. anthracite grey
4. dove grey
5. brown
6. amaranth
7. red

METAL FINISH

8. chromed
9. black nickel

METALL MAT LACKIERT

1. Weiss
2. Schwarz
3. Anthrazitgrau
4. Taubengrau
5. Braun
6. Amaranth
7. Rot

METALL AUSFÜHRUNG

8. Verchromt
9. Schwarz vernickelt

MÉTAL VERNI OPAQUE

1. blanc
2. noir
3. gris anthracite
4. gris tourterelle
5. marron
6. amarante
7. rouge

FINITION MÉTAL

8. chromé
9. noir nickel

DIMENSIONI / DIMENSIONS / GRÖÙEN / DIMENSIONS

LOVY

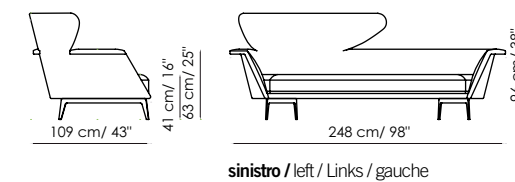

sinistro / left / Links / gauche

LOVY EGO



sinistro / left / Links / gauche

LOVY LOW

divano / sofa / Sofa / canapé

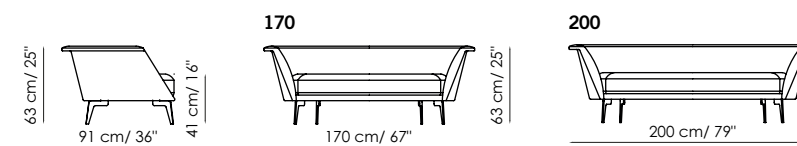

LOVY HI

divano / sofa / Sofa / canapé

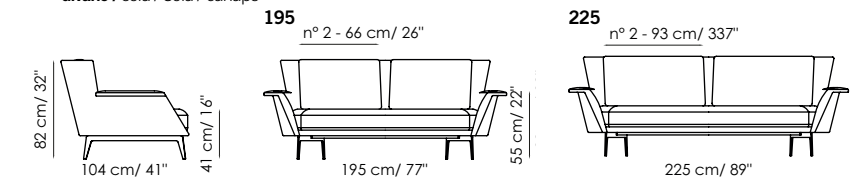

POUF

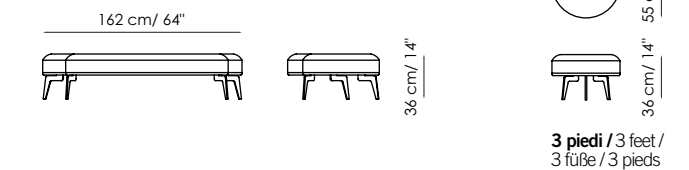

3 piedi / 3 feet / 3 FüÙe / 3 pieds

Cuscino / cushion / Kissen / coussin

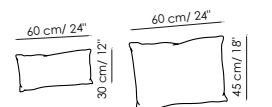

pag. 138, 139, 140, 141:
LOVY HI - divano 225 con 2 cuscini + pouf - tessuto MA56, piedi grigio antracite / sofa 225 with 2
cushions + pouf - fabric MA56, anthracite grey feet / canapé 225 avec 2 coussins + pouf - tissu MA56,
pieds gris anthracite / Sofa 225 mit 2 Kissen + Pouf - Stoff MA56, Anthrazitgraue FüÙe

pag. 142, 143:
LOVY EGO - sinistro, tessuto MC20, piedi black nickel / left, fabric MC20, black nickel feet / gauche, tissu
MC20, pieds black nickel / Links, Stoff MC20, Schwarz vernickelte FüÙe

CORTINA



1 RIVESTIMENTO / COVER / BEZUG / REVÊTEMENT

pelle leather Leder cuir souple
tessuto fabric tissu

2 PIEDI / FEET / FÜÙE / PIEDS

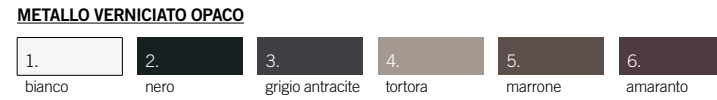

MAT PAINTED METAL
1. white
2. black
3. anthracite grey
4. dove grey
5. brown
6. amaranth

METALL MAT LACKIERT
1. Weiss
2. Schwarz
3. Anthrazitgrau
4. Taubengrau
5. Braun
6. Amaranth

MÉTAL VERNI OPAQUE
1. blanc
2. noir
3. gris anthracite
4. gris tourterelle
5. marron
6. amarante

DIMENSIONI / DIMENSIONS / GRÖÙEN / DIMENSIONS

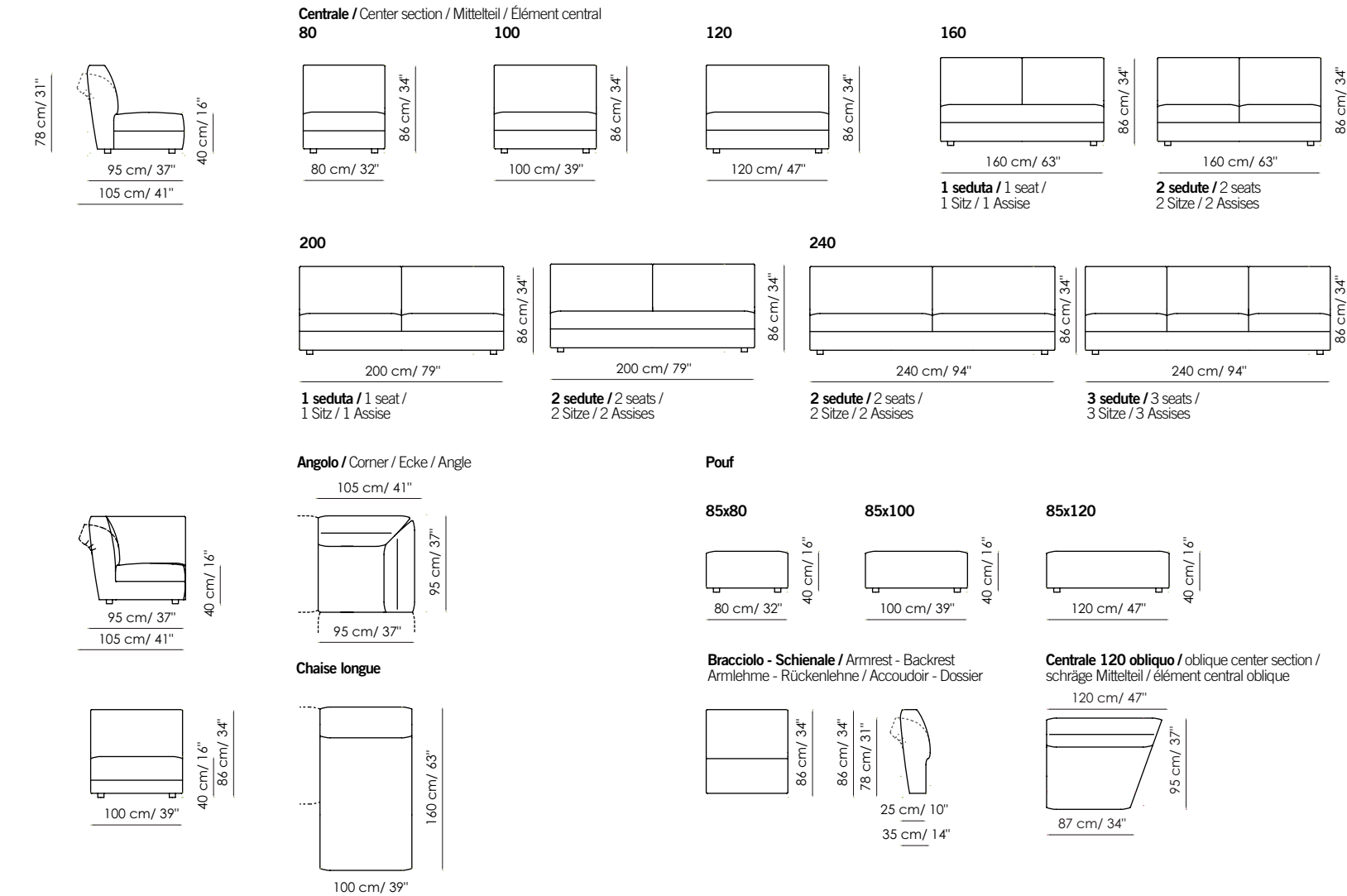

Tavolino / small table / Kleintisch / Petite table

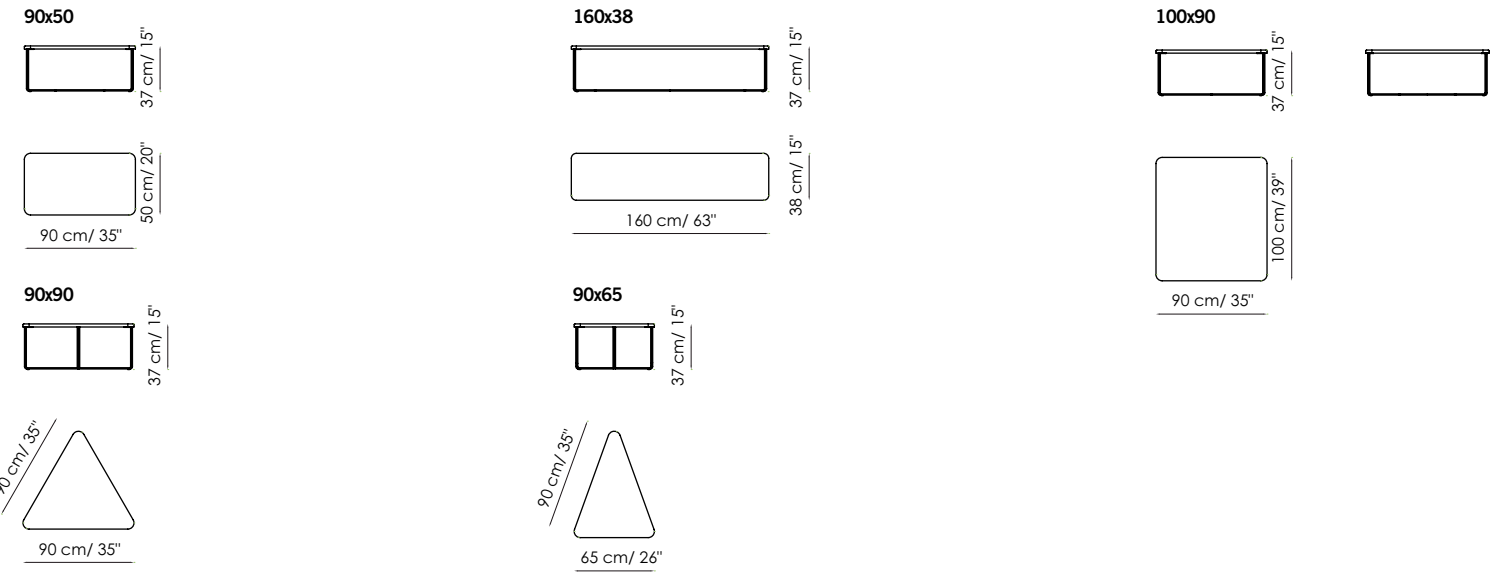

Portaoggetti / magazine rack / Zeitungständer / Porte revues



COMPOSIZIONE / COMBINATION / KOMBINATION / COMPOSITION

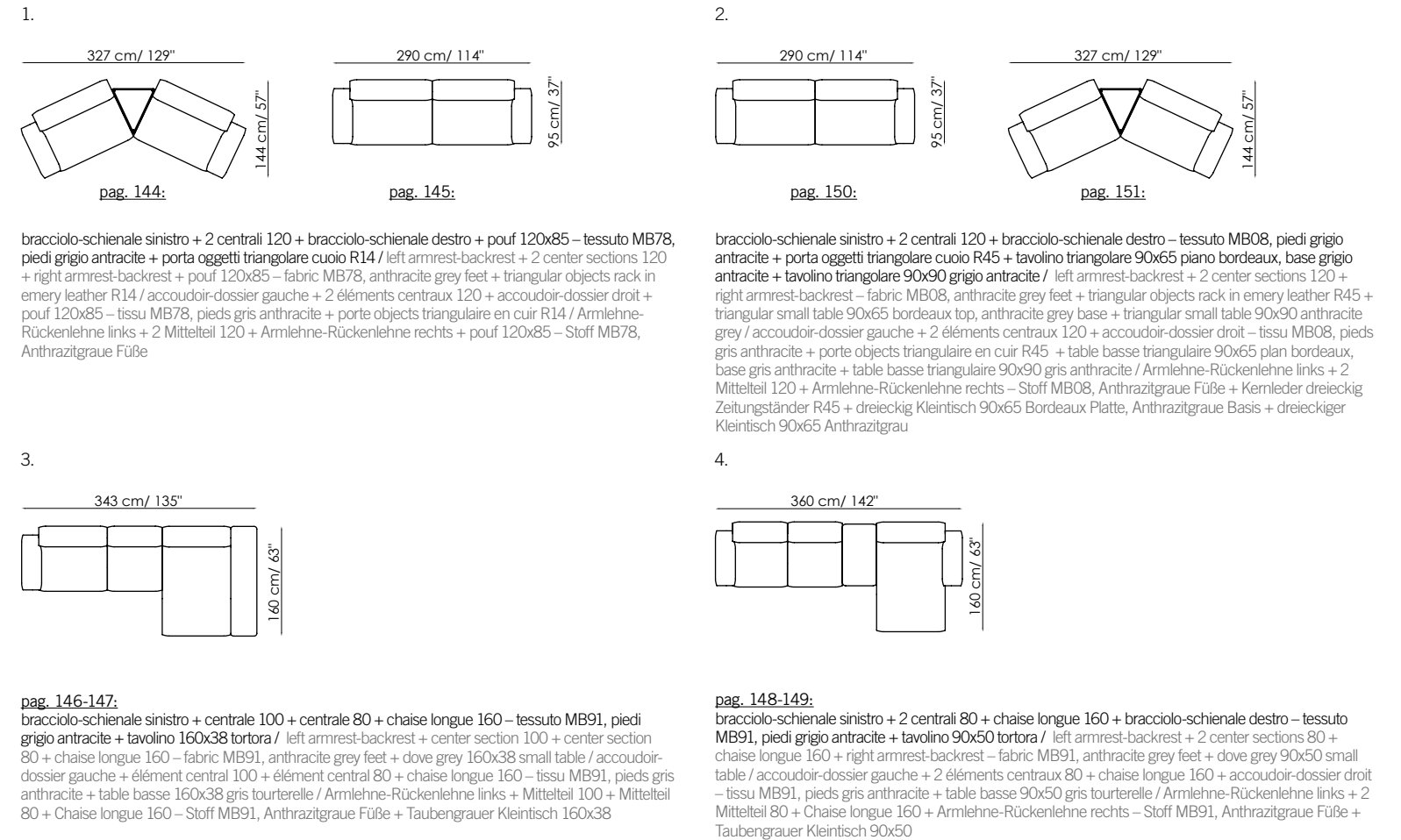

MADAME C.



1
RIVESTIMENTO / COVER / BEZUG / REVÊTEMENT

pelle tessuto	leather fabric	Leder Stoff	cuir souple tissu
------------------	-------------------	----------------	----------------------

2
PIEDI / FEET / FÛÈBE / PIEDS
(disponibile con base a slitta o piedi) / (available with sliding base or feet) /
(mit Kufenbasis oder FüÙe) / (disponible avec coulisse ou pieds)

METALLO VERNICIATO OPACO

1. bianco	2. nero	3. grigio antracite	4. tortora	5. marrone	6. amaranto
-----------	---------	---------------------	------------	------------	-------------

METALLO FINITURA

7. cromato	8. black nickel	9. rame opaco	10. ottone opaco
------------	-----------------	---------------	------------------

MAT PAINTED METAL 1. white 2. black 3. anthracite grey 4. dove grey 5. brown 6. amaranth	METALL MAT LACKIERT 1. Weiss 2. Schwarz 3. Anthrazitgrau 4. Taubengrau 5. Braun 6. Amaranth	MÉTAL VERNI OPAQUE 1. blanc 2. noir 3. gris anthracite 4. gris tourterelle 5. marron 6. amarante
METAL FINISH 7. chromed 8. black nickel 9. mat copper 10. mat brass	METALL AUSFÛHRUNG 7. Verchromt 8. Schwarz vernickelt 9. Kupfer matt 10. Messing matt	FINITION MÉTAL 7. chromé 8. noir nickel 9. cuivre opaque 10. laiton opaque

DIMENSIONI / DIMENSIONS / GRÖÙEN / DIMENSIONS

Divano / Sofa / Sofa / Canapé
210-230

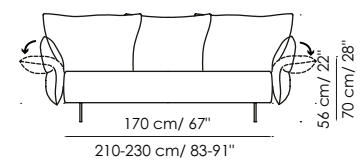

240-260

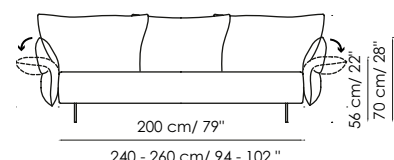

Terminale dx o sx / End section right or left / Endteill recht oder links / Élément terminal droite ou gauche
155-165

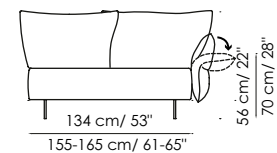

190-200

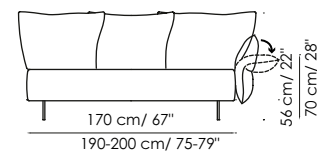

220-230

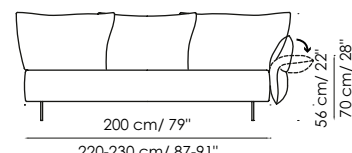

Angolo / corner / Ecke / Angle
143x143

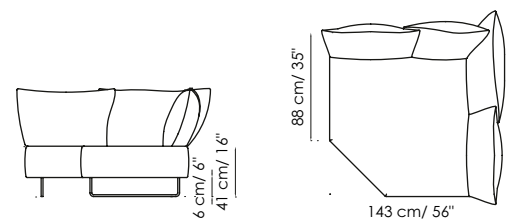

97x97

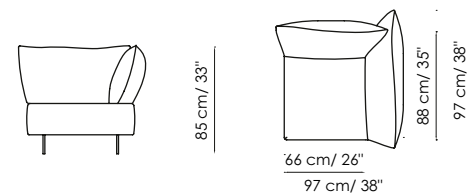

Meridiana dx o sx / right or left / recht oder links / droite ou gauche

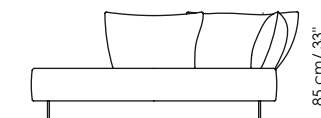
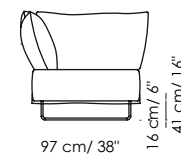

Chaise longue dx o sx / right or left / recht oder links / droite ou gauche

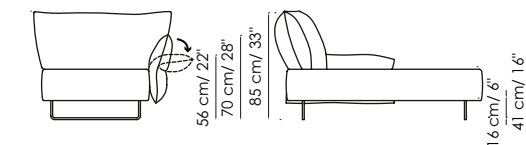

Pouf

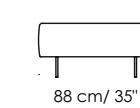
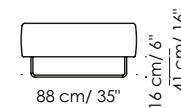
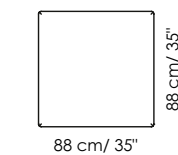

COMPOSIZIONE / COMBINATION / KOMBINATION / COMPOSITION

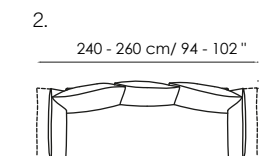
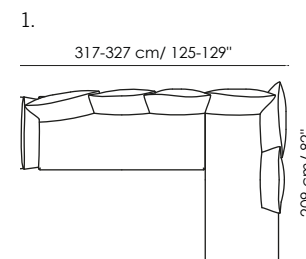

pag. 127, 128-129, 130, 131:
terminale 235 sx + meridiana sx – tessuto MA01, base a slitta grigio antracite / left end section 235 + left meridiana – fabric MA01, anthracite grey sliding base / élément terminal 235 gauche + meridiana gauche – tissu MA01, coulisse gris anthracite / Sofa Endteil 235 links + Meridiana links – Stoff MA01, Anthrazitgrau Kufen

pag. 132, 133:
divano 270 – tessuto SA37, piede grigio antracite / sofa 270 – fabric SA37, anthracite grey feet / tissu SA37, pied gris anthracite / Sofa 270 – Stoff SA37, Anthrazitgrau FüÙe

Nei disegni di Madame C, tutti gli elementi che offrono la possibilità di scelta destra o sinistra, per omogeneità di rappresentazione, sono illustrati nel verso destro (se non diversamente specificato). In the drawings of Madame C, all the elements that offer the right or left choice are shown as right (unless otherwise specified), due to homogeneity of representation. In den Zeichnungen des Madame C die rechts oder links Wahlausführung anbieten, wegen Homogenität der Darstellung, mit rechte Ausrichtung dargestellt (wenn nicht anders angegeben). Dans les dessins de Madame C, tous les éléments qui offrent le choix de droite ou de gauche sont montrés dans la version droite (sauf indication contraire), pour homogénéité de représentation.



1
RIVESTIMENTO / COVER / BEZUG / REVÊTEMENT

pelle / leather / Leder / cuir souple
tessuto / fabric / Stoff / tissu

2
PIEDI / FEET / FÜÙE / PIEDS

LEGNO COLOR / PAINTED WOOD / HOLZ / BOIS TEINTÉ
1. grigio antracite / 1. anthracite grey / 1. Anthrazitgrau / 1. gris anthracite

DIMENSIONI / DIMENSIONS / GRÖÙEN / DIMENSIONS

Divano / Sofa / Sofa / Canapé 200

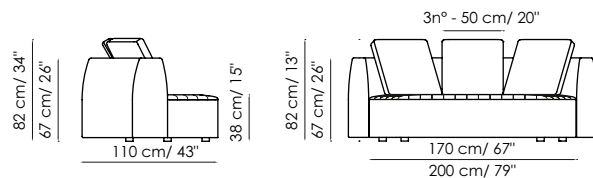

230

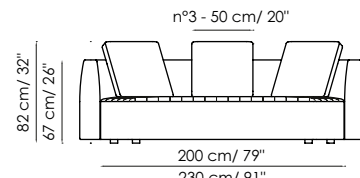

260

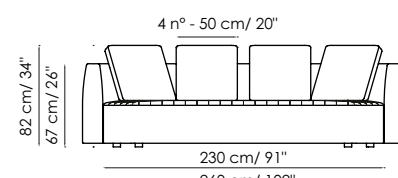

Terminale dx o sx / End section right or left / Endteil recht oder links / Élément terminal droite ou gauche 235

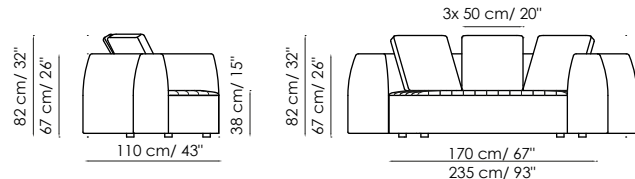

Cuscino / cushion / Kissen / coussin

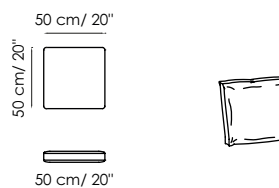

Cuscino ego / cushion / Kissen / coussin

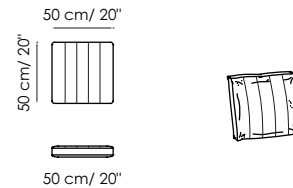

Pouf

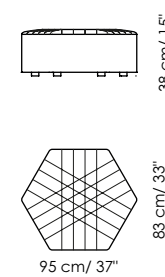

Pouf con ruote / with castors / mit Räder / avec roulettes

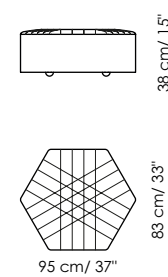

Poltrona / Armchair / Sessel / Fauteuil

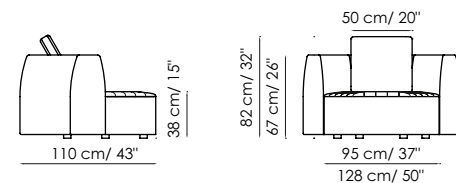

COMPOSIZIONE / COMBINATION / KOMBINATION / COMPOSITION

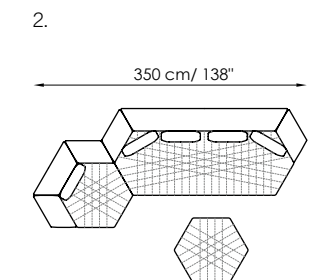
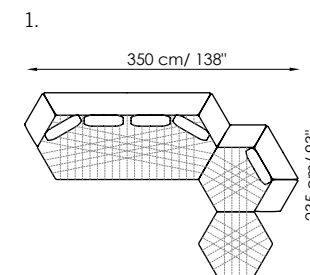

pag. 116-117, 118, 119:
divano 200 – tessuto 9B17 + poltrona + pouf – tessuto MC14 / sofa 200 – fabric 9B17 + armchair + pouf – fabric MC14 / canapé 200 – tissu 9B17 + fauteuil + pouf – tissu MC14 / Sofa 200 – Stoff 9B17 + Sessel + Pouf – Stoff MC14

pag. 120-121, 122, 123:
divano 200 + poltrona + pouf – tessuto 97K / sofa 200 + armchair + pouf – fabric 97K / canapé 200 + fauteuil + pouf – tissu 97K / Sofa 200 + Sessel + Pouf – Stoff 97K

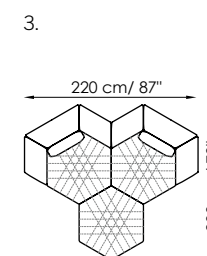

pag. 125:
poltrona – tessuto MC75, MC43 + pouf con ruote – tessuto MC75 / armchair – fabric MC75, MC43 + pouf on wheels – fabric MC75 / fauteuil – tissu MC75, MC43 + pouf avec roulettes – tissu MC75 / Sessel – Stoff MC75, MC43 + Pouf mit Räder – Stoff MC75

Nei disegni di Panorama, tutti gli elementi che offrono la possibilità di scelta destra o sinistra, per omogeneità di rappresentazione, sono illustrati nel verso destro (se non diversamente specificato). In the drawings of Panorama, all the elements that offer the right or left choice are shown as right (unless otherwise specified), due to homogeneity of representation. In den Zeichnungen des Panorama die rechts oder links Wahlauführung anbieten, wegen Homogenität der Darstellung, mit rechte Ausrichtung dargestellt (wenn nicht anders angegeben). Dans les dessins de Panorama, tous les éléments qui offrent le choix de droite ou de gauche sont montrés dans la version droite (sauf indication contraire), pour homogénéité de représentation.

KENOBI



1 RIVESTIMENTO / UPHOLSTERY / BEZUG / REVÊTEMENT

tessuto fabric Stoff tissu

2 PIEDI / FEET / FÜÙE / PIEDS

METALLO VERNICIATO OPACO

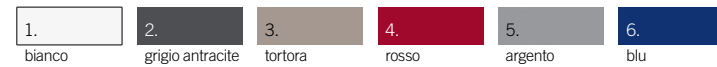

MAT PAINTED METAL

1. white
2. anthracite grey
3. dove grey
4. red
5. silver
6. blue

METALL MAT LACKIERT

1. Weiss
2. Anthrazitgrau
3. Taubengrau
4. Rot
5. Silber
6. Blau

MÉTAL VERNI OPAQUE

1. blanc
2. gris anthracite
3. gris tourterelle
4. rouge
5. argent
6. bleu

DIMENSIONI / DIMENSIONS / GRÖÙEN / DIMENSIONS

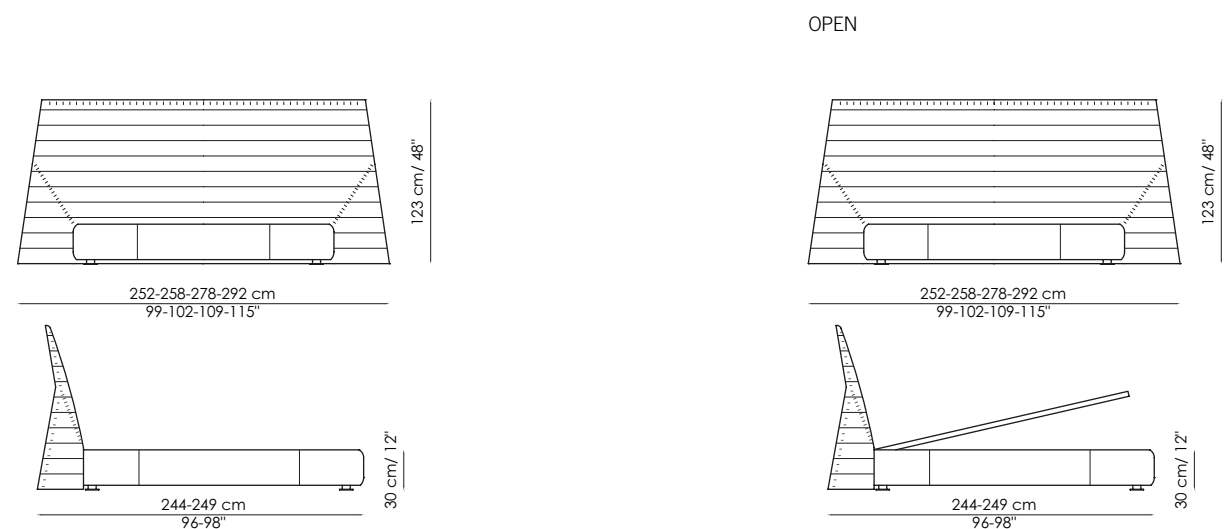

pag. 160, 161, 162-163, 164-165.
rete / bed base / sommier / Lattenrost 180x200 cm – tessuto MA43, piedi tortora / fabric MA43, dove grey
feet / tissu MA43, pieds gris tourterelle / Stoff MA43, Taubengraue FüÙe

YOUNIVERSE



1 RIVESTIMENTO / UPHOLSTERY / BEZUG / REVÊTEMENT

pelle tessuto fabric Stoff tissu

2 PIEDI / FEET / FÜÙE / PIEDS

METALLO VERNICIATO OPACO



MAT PAINTED METAL

1. white
2. anthracite grey
3. dove grey
4. red
5. silver
6. blue

METALL LACKIERT MATT

1. Weiss
2. Anthrazitgrau
3. Taubengrau
4. Rot
5. Silber
6. Blau

MÉTAL VERNI OPAQUE

1. blanc
2. gris anthracite
3. gris tourterelle
4. rouge
5. argent
6. bleu

DIMENSIONI / DIMENSIONS / GRÖÙEN / DIMENSIONS

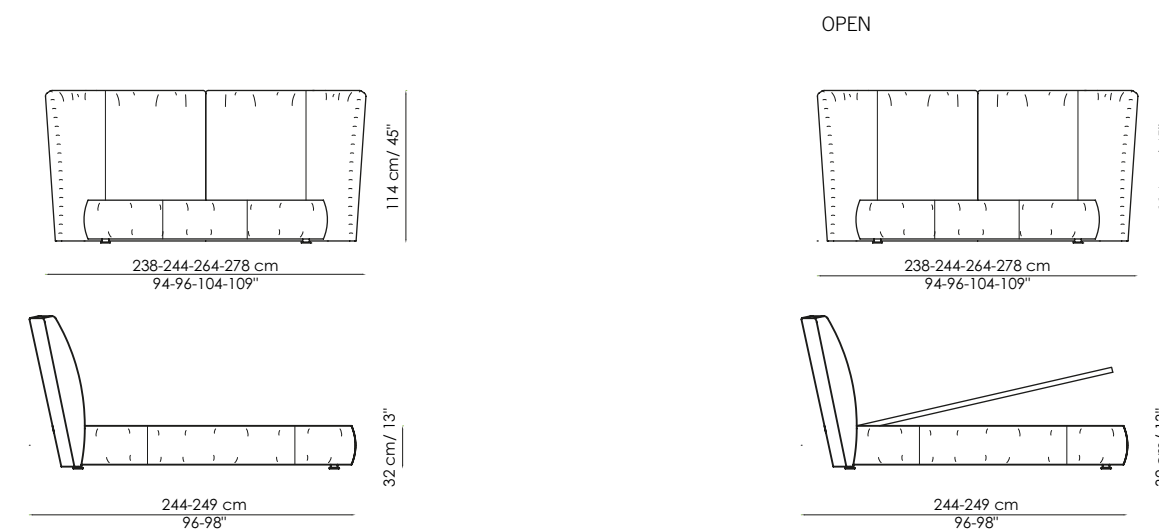

pag. 154, 155, 156-157, 158-159.
rete / bed base / sommier / Lattenrost 180x200 cm – tessuto MB52, piedi grigio antracite / fabric MB52,
anthracite grey feet / tissu MB52, pieds gris anthracite / Stoff MB52, Anthrazitgraue FüÙe

Ceramica / Ceramic / Keramik / Céramique



ceramica Onice oro
Gold Onice ceramic
Gold Onice Keramik
céramique Onice d'or

Terrazzo / Terrazzo / Terrazzo / Terrazzo

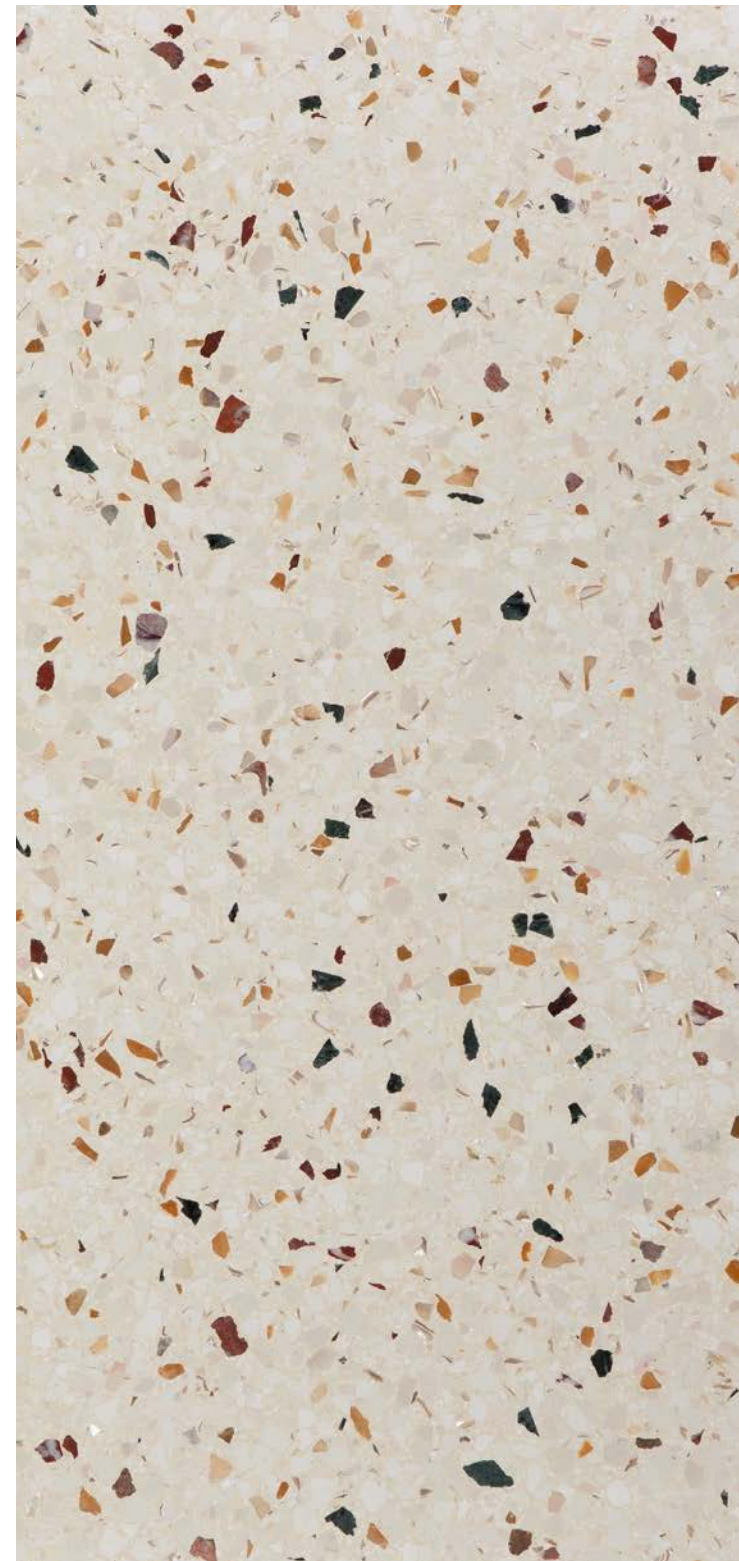

bianco
white
Weiss
blanc

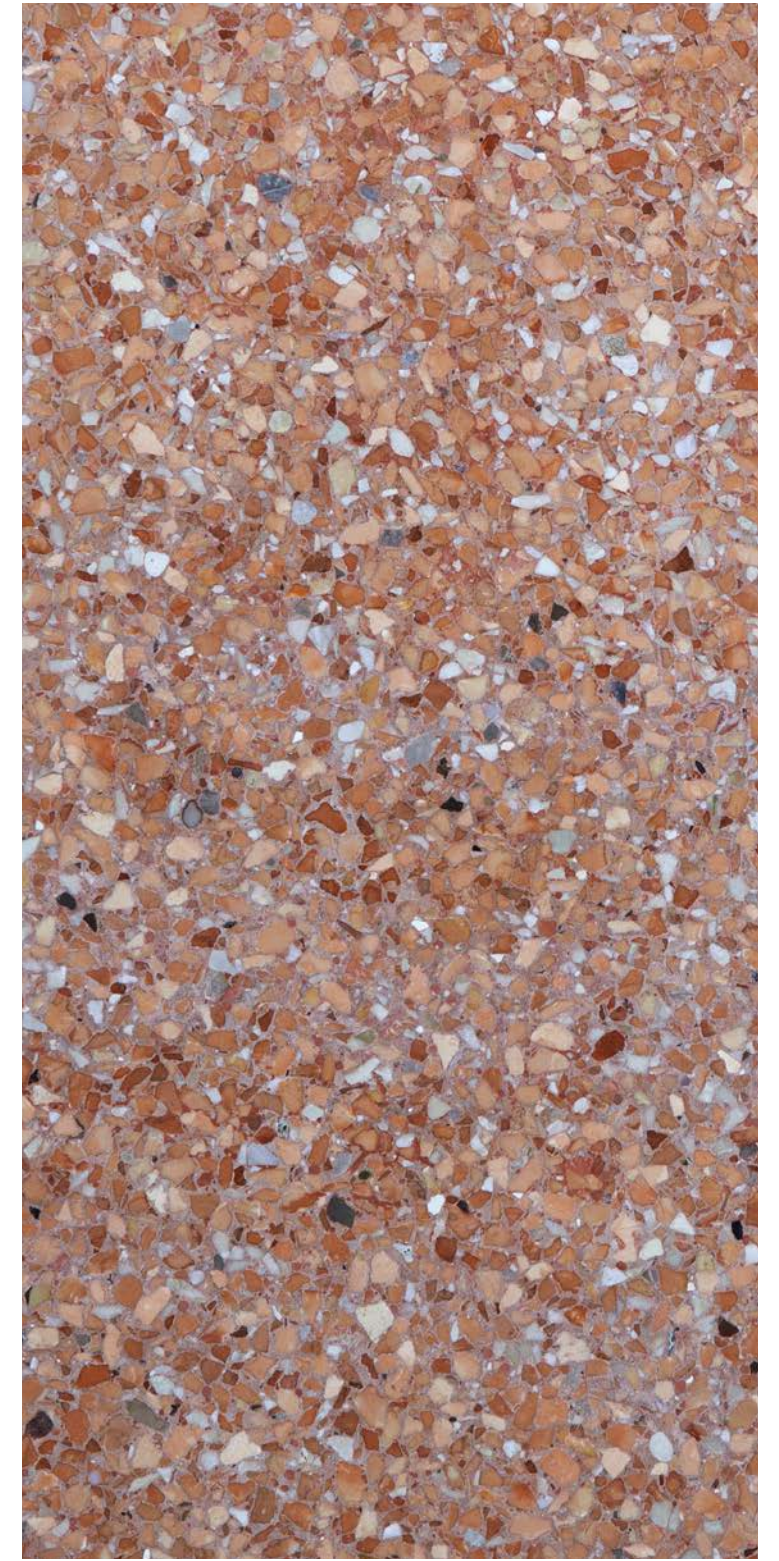

rosa
pink
Rosa
rose

concept

romanoassociati.com

photographer

Paolo Golumelli

stylingLaura Cazzaniga
Ilaria Limonta**press**

Grafiche Antiga

stampato
con il sole**printed in Italy**

July 2018

thanks toBitossi Ceramiche
CC-Tapis
dix heures dix
Fontana Arte
Incipit
Penta

Bonaldo SpA si riserva il diritto di modificare, senza preavviso, materiali, rivestimenti, finiture e disegni dei prodotti presentati in questo catalogo.

I colori e le finiture visualizzate sono puramente indicativi e possono differire dagli originali. Le immagini riprodotte nel presente catalogo sono di proprietà esclusiva di Bonaldo SpA.

È vietata qualunque riproduzione o utilizzo delle immagini senza preventiva autorizzazione scritta di Bonaldo SpA.

Bonaldo SpA reserves the right to change, without any notice, materials, covers, finishes and drawings of the products presented in this catalogue.

Colors and finishes shown are approximate and may differ from actual ones. All images in this catalogue are exclusive property of Bonaldo SpA.

Every reproduction or use of the images without prior written authorization from Bonaldo SpA is therefore strictly forbidden.

Bonaldo SpA behält sich das Recht vor, ohne vorherige Ankuendigung, Materialien, Ersatzbezeuge, Ausfuehrungen und Zeichnungen der in diesem Katalog vorgestellten Produkte zu aendern.

Die dargestellten Farben und Ausfuehrungen sind ungefaehre Angaben und koennen von den Originalen abweichen. Die in diesem Katalog abgebildete Bilder sind ausschliesslich Eigentum von Bonaldo SpA.

Ohne die vorherige schriftliche Genehmigung von Bonaldo SpA. ist es jede Vervielfaeltigung oder Verwendung von Bildern verboten.

Bonaldo SpA se réserve le droit de modifier, sans préavis, les matériaux, les revêtements, les finitions et les dessins des produits présentés dans ce catalogue. Les couleurs et les finitions indiquées sont indicatives et peuvent différer des originaux. Les images reproduites dans ce catalogue sont propriété exclusive de Bonaldo SpA.

Il est interdit la reproduction ou utilisation d'images sans l'autorisation écrite préalable de Bonaldo SpA.

BONALDO

Bonaldo SpA_ via Straelle, 3_35010 Villanova di Camposampiero (PD) Italy
tel + 39 049.9299.011 bonaldo@bonaldo.it www.bonaldo.it

WWW.BONALDO.IT

